

Alberta Transmission System
2006 Transmission Cost Causation Update
July 4, 2006 — DRAFT

Prepared for the
Alberta Electric System Operator (AESO)

PS Technologies
Arnie Reimer, P. Eng.

Table of Contents

| | |
|--|-----------|
| 1. Overview..... | 2 |
| 2. Bulk System Demand Related Costs..... | 3 |
| 2.1 Cost Causation Update Activities | 5 |
| 2.2 Factors that Drive Bulk System Upgrades | 7 |
| 2.2.1. Alberta Internal Load (AIL)..... | 7 |
| 2.2.2. Interviews with Transmission Planners | 8 |
| 2.2.3. Coincidence between Bulk System Load and AIL Load | 12 |
| 2.2.4. Percent Loading based on Thermal Capacity | 21 |
| 2.3 Summary – Classification of Bulk System | 26 |
| 2.3.1. Classification of Bulk System Costs | 27 |
| 3. Interprovincial Ties | 31 |
| 3.1 NBV of Interprovincial Interconnections | 32 |
| 3.2 Summary..... | 33 |
| 4. Local System | 34 |
| 4.1 Alignment With Contribution Policy | 37 |
| 4.2 Conclusion | 38 |
| 5. POD Costs..... | 39 |
| 6. Contributions in Aid of Construction (CIAC)..... | 40 |
| 7. Dual Use Substations | 42 |
| 8. Operations, Maintenance and Administration | 45 |
| 9. Recommended Additional Activities | 47 |
| 10. Appendix A | 4 |

1. OVERVIEW

The AESO commissioned the study of cost causation within the transmission system in order to better understand costs, to assist with the design of the structure of the transmission tariff and to fulfill EUB directions to review costs. The Transmission Cost Causation Study (TCCS) was filed as part of the AESO 2005-2006 General Tariff Application. The EUB considered the report to be “a good first step” (Decision 2005-096, p. 24) at an in depth review of cost causation for an electric transmission system.

The AESO and various stakeholders identified several activities for further study, based in large part on directions and comments provided by the EUB in Decision 2005-096. The activities for further study as described in the Terms of Reference dated February 16, 2006, are provided in Appendix A.

This Transmission Cost Causation Update addresses several of the activities listed in the Terms of Reference found in Appendix A. Each activity has its own overview and summary.

2. BULK SYSTEM DEMAND RELATED COSTS

The Transmission Cost Causation Study (TCCS) identified Bulk System costs that were demand and energy related. The nature of the demand related costs and how they are incurred is the subject of this section. The TCCS defined a new term: Coincident Load at time of Maximum Stress (CLMS), because it was evident that the bulk transmission system is designed to meet the maximum stress coincident on the system components of concern, rather than on the basis of one overall system.

The rationale for Bulk System additions are complex. Additions to the Bulk System are required when the Bulk System becomes stressed. In the AESO's 2005-2006 GTA, interveners suggested that demand related costs be classified on the basis of coincident peak demand to best reflect cost causation. This section tests the relationship between coincident peak load and maximum stress on the system.

Maximum stress in the Bulk System is a situation where transmission planning criteria are in violation, and an upgrade is required to alleviate the violation. Stress results when there is violation of limits with respect to one or more of the following parameters:

- Thermal capacity,
- Voltage,
- Stability

The electrical system is modeled on a forecast load basis and each of these parameters are tested to ensure compliance with planning criteria. Violation of thermal capacity is easiest to demonstrate as follows: A line has a thermal rating of 500 MVA in the winter, and 400 MVA in the summer. If the line is loaded at 450 MVA for the entire year, the line is at 90% of its thermal capacity in the winter and is at 113% of its thermal

capacity in the summer. This line experiences maximum stress in the summer even though its load is constant throughout the year.

Thermal capacity is easy to understand because each transmission component has a rating that can be compared to loading to see if there is an overload. Stress regarding voltage or stability is more difficult to understand because these parameters are determined through the interaction of a large number of transmission components. For example, low voltage can occur in an area as the result of conditions elsewhere on the system.

This study finds that for Alberta as a whole, the correlation between the time of maximum stress on the Bulk System and the time of peak system load is weak. For most areas of Alberta, the time of maximum stress on the Bulk system does not coincide with the time of peak system load. The northwest part of Alberta is the only area where the time of maximum stress on the Bulk system coincides with the time of peak system load.

The time of maximum stress on the Bulk System is driven by a number of variables including the location of generation and load, the profiles (daily and seasonally) of generation and load, and the configuration of the electric transmission system in Alberta. The time of maximum stress on the Bulk system cannot be reliably predicted by considering the peak system load in Alberta. The maximum demand at each POD is a more appropriate indicator of contribution to stress on the Bulk System.

The Bulk System is planned to meet the demand for electricity, and the issue has been, demand on what basis. The system CP demand is a poor indicator of stress on the Bulk System and the peak demand at the POD's is a more reliable and predictable indicator of cost causation for the Bulk System.

2.1 Cost Causation Update Activities

The first area identified by the AESO for further study is the Bulk System, and specifically the time that the Bulk System is stressed as follows:

Study all of the major bulk paths (between 20 and 30 paths) to determine the relationship between the time of maximum stress and the time of peak system load. Review the functionalization of bulk system and local system to ensure continuing consistency with AESO planning. This study component would primarily use technical data from the 500 kV N-S Need Application as the basis, as well as additional data from more recent planning studies prepared by the AESO, if necessary.

The use of technical data from the 500 kV N-S Need Application is not practical because the Application did not provide data for lines in other areas. In order to study the relationship between maximum stress and system peak load, further research and other data sources are required.

A common hypothesis is that the Bulk System is most heavily loaded and stressed at the time of system peak load. This hypothesis has been the basis for classifying demand related costs of transmission to load on the basis of coincident peak load (CP). The process of classifying all costs to the single annual coincident peak load (system peak load) is commonly referred to as 1 CP. Variations on this method of classifying costs include the classification of costs to each monthly coincident peak load. When each month is weighted equally, the method is known as 12 CP. Other variations include different weightings by month to allow heavier weights for months that planners focus on when determining the adequacy of the transmission system.

The TCCS studied the rationale for Bulk System upgrades, and determined there are times or conditions that contribute to

maximum stress on the Bulk System, and the term Coincident Load at the time of Maximum Stress (CLMS) was developed. The TCCS found that the CLMS was not necessarily coincident to the system peak load. In the case of the North-South 500 kV upgrade, the load on two paths was closest to the thermal rating of the path during light system load periods. The TCCS also identified that 55% of points of delivery experienced peak load conditions in the winter, and 45% experienced peak load conditions in other periods.

Two paths were studied in the TCCS study, and participants are interested in a more in depth study of the correlation between the system load, and the conditions that drive Bulk System capital expansions.

The study of the correlation between system load and factors that drive Bulk System expansions is challenging, because there are several independent factors, identified in the previous section, that planners consider when determining the need for system upgrades. The following section studies factors that cause Bulk System upgrades.

2.2 Factors that Drive Bulk System Upgrades

This section explores the requirements to upgrade the Bulk System, and also tests the hypothesis that peak system load drives the need for Bulk System upgrades.

This study consists of the following three sections:

- a) Interviews with planners to review transmission paths and the need to upgrade the system to accommodate load growth,
- b) A study of correlation between loading on Bulk System components (240 kV lines) and system peak load, and
- c) A study of correlation between line loading as percent of thermal capacity and system peak load.

The correlation studies consider the number of lines, the kM of lines, and the Net Book Value (NBV) of the lines.

2.2.1. Alberta Internal Load (AIL)

Alberta Internal Load (AIL) represents the total domestic consumption of Alberta Interconnected Electric System (AIES) loads in Alberta. The AIL annual load profile in Alberta has changed over the years. In the past, Alberta had a strong winter peak load. With the addition of irrigation, air conditioning and industrial load, the winter peaks are no longer as dominant as they once were. Southern Alberta electrical load has become summer peaking load, and in combination with lower thermal capacity in the summer, the transmission system in southern Alberta is not constrained in the winter time. The electrical load in Calgary and Edmonton peaks in the winter in some years, and in the summer in other years, depending on the weather. Overall in Alberta, the summer peak load in 2005 was approximately 90% of the winter peak load. The following chart shows the monthly peak load in Alberta for 2005.

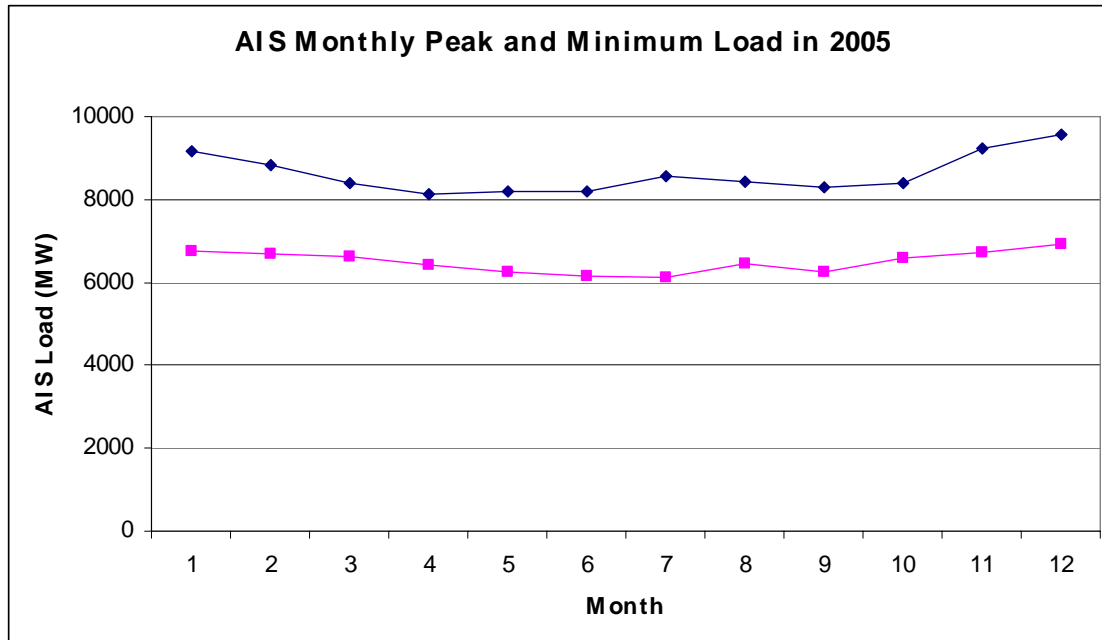

2.2.2. Interviews with Transmission Planners

During the AESO's 2005-2006 GTA proceeding, there was discussion of some 20 or 30 major transmission bulk paths that planners may consider when studying the transmission system. The transmission planners have no standard definition regarding what constitutes a transmission path. Transmission planners may consider cut planes as the lines that separate various regions. The flow across a cut plane is a function of the load and generation in a region, and the flow of electricity will take the path of least resistance and will flow in all lines crossing the cut plane. It is not possible to positively identify the precise number of major transmission paths and the loading in those paths because there is no universally applicable definition of a path. Transmission planners study a particular area and problem, and may consider a path a number of lines that have parallel flows, especially where outages to one line impact the flows on other lines in the path.

The transmission planners were interviewed to document transmission paths, and the time at which maximum stress occurs on the path, and the relationship between the time of maximum stress and the time of peak AIL load. The following table is the author's compilation of points that planners consider when studying the system to determine the adequacy of the transmission system to meet forecast load growth.

| Description of Path or Transmission Facilities | Constraining Factor | Cause of Constraining Factor and correlation to AIL Peak Load |
|---|------------------------------|---|
| Southern Alberta | | |
| 944L/951L | Voltage and thermal capacity | Load plus export causes constraint. Load in area is primarily industrial (flat) and export to Saskatchewan varies. Export conditions independent of AIL load. |
| 923L/924L/911L South of Milo | Thermal capacity and voltage | Peak load conditions driven by wind power generation. Wind generation not correlated to AIL load, thermal constraints occur in summer versus maximum AIL load occurs in winter. |
| 923L/924L west of Brooks | Currently under review | Coal fired generation from Sheerness and future Brooks plant plus wind generation. Coal is considered base load and wind generation will cause peak loading. Wind generation is not correlated to AIL load. |
| SE Area 240 kV upgrade | Thermal capacity | Projected wind generation. Wind generation is not correlated to AIL load, and thermal constraints will occur in summer. |
| 933L/934L/950L South of Anderson | Under review | |
| SW Upgrade – Pincher Creek Area | Thermal capacity and voltage | Wind generation causes high loading. Wind generation not correlated to AIL load. Thermal constraints will occur in summer versus maximum AIL load in winter |
| Central Alberta | | |
| 6 – 240 kV circuits between Edmonton and Calgary | Voltage | Heavy summer load and no import |

| Description of Path or Transmission Facilities | Constraining Factor | Cause of Constraining Factor and correlation to AIL Peak Load |
|---|--|---|
| 6 – 240 kV circuits between Edmonton and Calgary | Thermal capacity | High load in summer with no import, and lighter loads as exports increase. |
| 6 – 240 kV circuits between Edmonton and Calgary | Stability | Light load coupled with heavy export (independent of season). |
| Northern Alberta | | |
| 7L62/7L58/7L82 | Voltage and thermal capacity | TMR is currently used to alleviate voltage violations and thermal capacity constraints. NW load is generally coincident to AIL load, and peaks in winter. |
| Grand Prairie NW-9 | Voltage | Winter peak load, which is generally coincident to AIL peak load |
| NE Area (Fort MacMurray) | Voltage and stability, OPP limits area imports and exports | Peak load conditions generally driven by generation, or generator outage. These factors are not correlated to time of AIL peak load. |
| NE Path from Edmonton to Ft Sask | Voltage and thermal capacity | Voltage and thermal capacity constraints occur during contingencies. Thermal capacity constraints occur in summer. |

Based on the interviews with transmission planners, transmission upgrades in southern Alberta are driven by constraints that occur in summer, and therefore do not coincide with the time of annual AIL peak load. Transmission upgrades in northern Alberta are driven by constraints that occur during peak load conditions in winter, which generally coincide with the time of AIL peak load, or constraints are driven by generation, which does not coincide with the time of AIL peak load.

This qualitative assessment shows that transmission planning is very complex and is not dominated by any one simple factor such as AIL peak

load. Transmission planning is driven by a large number of independent factors such as the location of generation and load, the profiles (daily and seasonally) of generation and load, and the configuration of the electric transmission system in Alberta.

2.2.3. Coincidence between Bulk System Load and AIL Load

In addition to the qualitative assessments in Section 2.2.2, quantitative analysis was undertaken to determine the correlation between the time of maximum stress on the Bulk System and the AIL load. This exercise must be simplified because maximum stress can occur for a number of different reasons. One way to simplify the issue for study is to simply consider loading on Bulk System components. While this may provide some insight, it does not fully reflect how the system is planned, because the system is planned as a whole and considers interaction between components. This was accomplished by obtaining meter data for 240 kV circuits that were in service during 2003, when the original data for the Transmission Cost Causation Study was obtained. For this analysis, the 240 kV circuits are considered to reasonably represent the Bulk System. Meter data was obtained for each 240 kV circuit, by hour, for 2005. The AIL load by hour was also obtained by hour for 2005. Since all meter data is actual data, this analysis has some shortcomings. For example, transmission planning is done on the basis of no opportunity sales, whereas actual meter data does include any opportunity sales that occurred. The meter data includes actual imports and exports. No provision is made to adjust meter data for abnormal conditions such as transmission contingencies or generator outages. The lack of correction for these conditions is not expected to influence the conclusions. The impact of some of these conditions is discussed below.

The actual meter data for 2005 includes exports of 1,038 GWh that accounts for approximately 1.5% of the total load. There was one major

transmission contingency in 2005 that occurred when a tornado damaged transmission lines and customers facilities in the Empress area and service was restored in less than 2 weeks.

The hourly load data for each circuit was analysed with respect to the AIL load to determine the correlation between the two. The hourly load for each circuit, and the hourly AIL load was analysed to determine the Pearson correlation coefficient. The Pearson correlation coefficient is a dimensionless index that ranges from -1.0 to $+1.0$ inclusive and reflects the extent of a linear relationship between two data sets. More information on the Pearson Coefficient can be found on the internet by Eric W. Weisstein. "Correlation Coefficient." From [MathWorld](http://mathworld.wolfram.com/CorrelationCoefficient.html) — A Wolfram Web Resource at the following link:

<http://mathworld.wolfram.com/CorrelationCoefficient.html>

A coefficient of -1.0 indicates an inversely proportional perfectly linear relationship between the two data sets, while a coefficient of $+1.0$ indicates a directly proportional perfectly linear relationship, as shown in the following examples.

Figure 1 Pearson Coefficient of -1 (Inversely Proportional Linear Relationship)

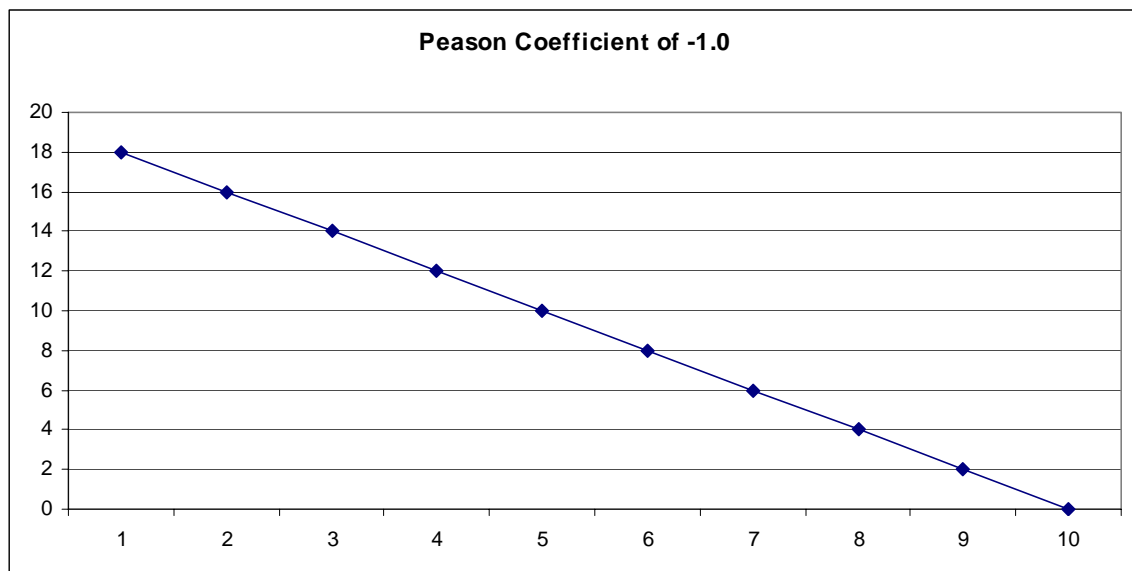
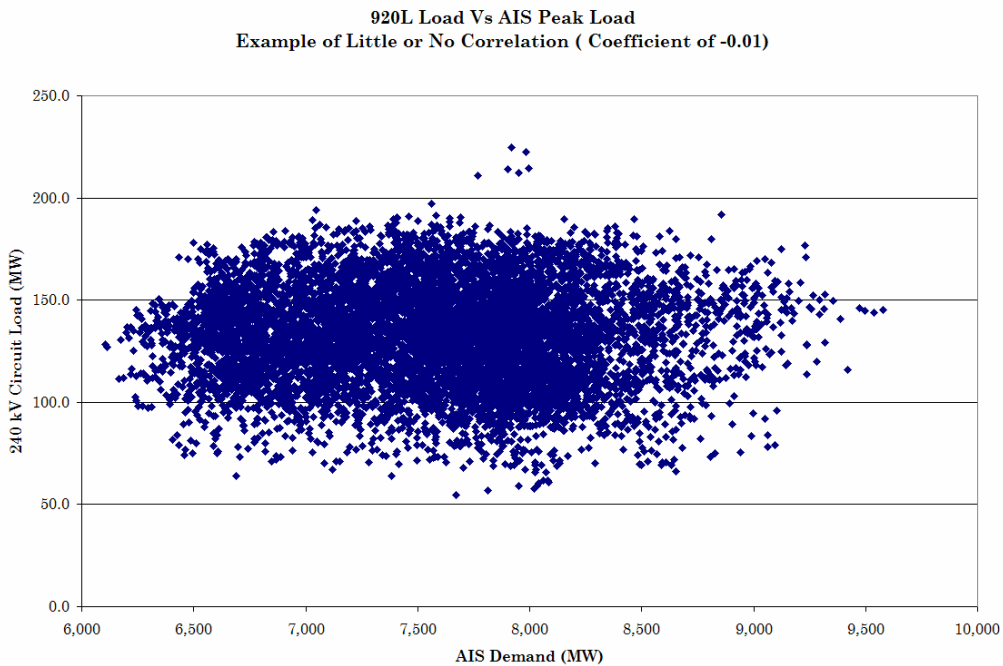

Figure 2 Pearson Coefficient of +1 (Directly Proportional Linear Relationship)



A Pearson coefficient of 0 indicates that there is no correlation between the two datasets. The following example is of 920L, a 240 kV circuit from Edmonton to Fort Saskatchewan, which has a Pearson coefficient of closest to zero. The Pearson coefficient for 920L is -0.012 .

Figure 3 Pearson Coefficient of Near 0 (Independent Variables)



Meter data, by hour for 2005 was obtained for 240 kV circuits. The correlation between the circuit load and AIL load was analyzed to determine a correlation coefficient. A total of seventy nine 240 kV circuits were studied for line loading correlation to AIL load which represents 93% of the 240 kV transmission lines on the basis of NBV. The 240 kV circuits included 58 AltaLink circuits and 21 Atco Electric circuits. In total, 66% of the circuits (52 of 79) exhibited correlation coefficients of greater than zero indicating that line loading is generally proportional to AIL load while the other 34% of the circuits (27 of 79) exhibited negative correlation coefficients which indicates that circuit loading is inversely proportional to AIL load.

The circuit with the strongest positive correlation coefficient was 917L with a correlation coefficient of 0.7 and the circuit with the strongest negative correlation coefficient was 916L, which is also located in Calgary and has a correlation coefficient of -0.54 as shown below.

Figure 4 240 kV Circuit with Strongest Negative Correlation.

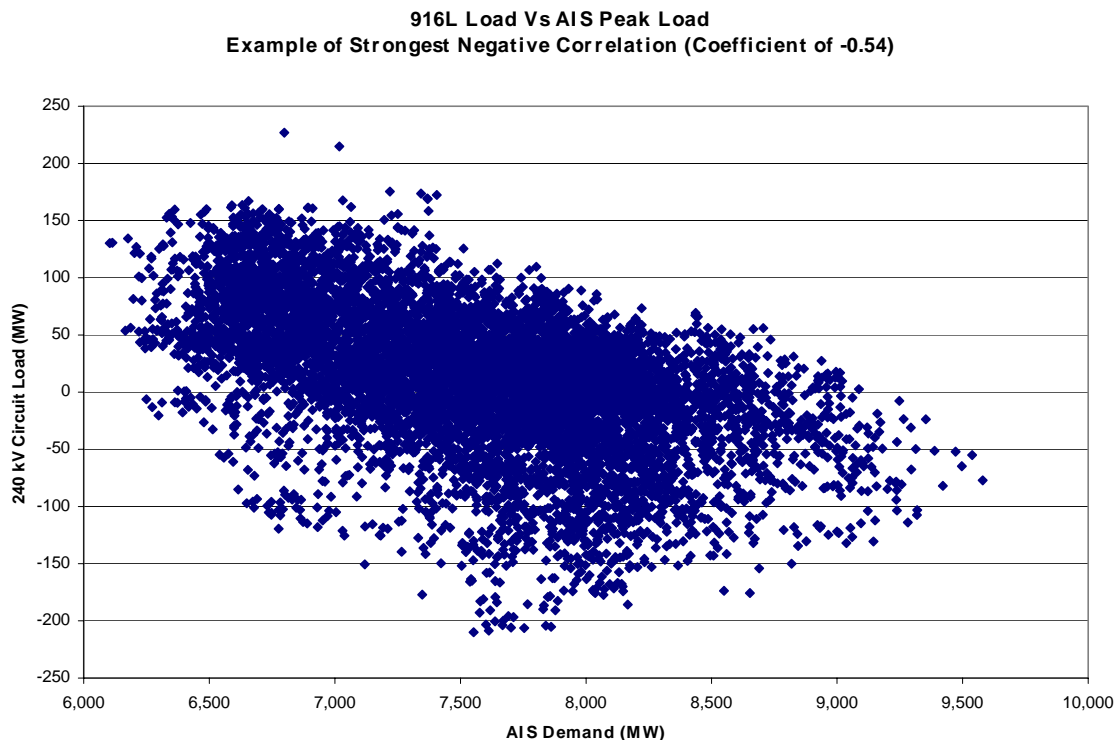

The 240 kV circuit with the strongest positive correlation between line loading and AIS load was 917L, which is in the Calgary area with a correlation coefficient of 0.70 as shown in the following figure.

Figure 5 240 kV Circuit with Strongest Positive Correlation Coefficient

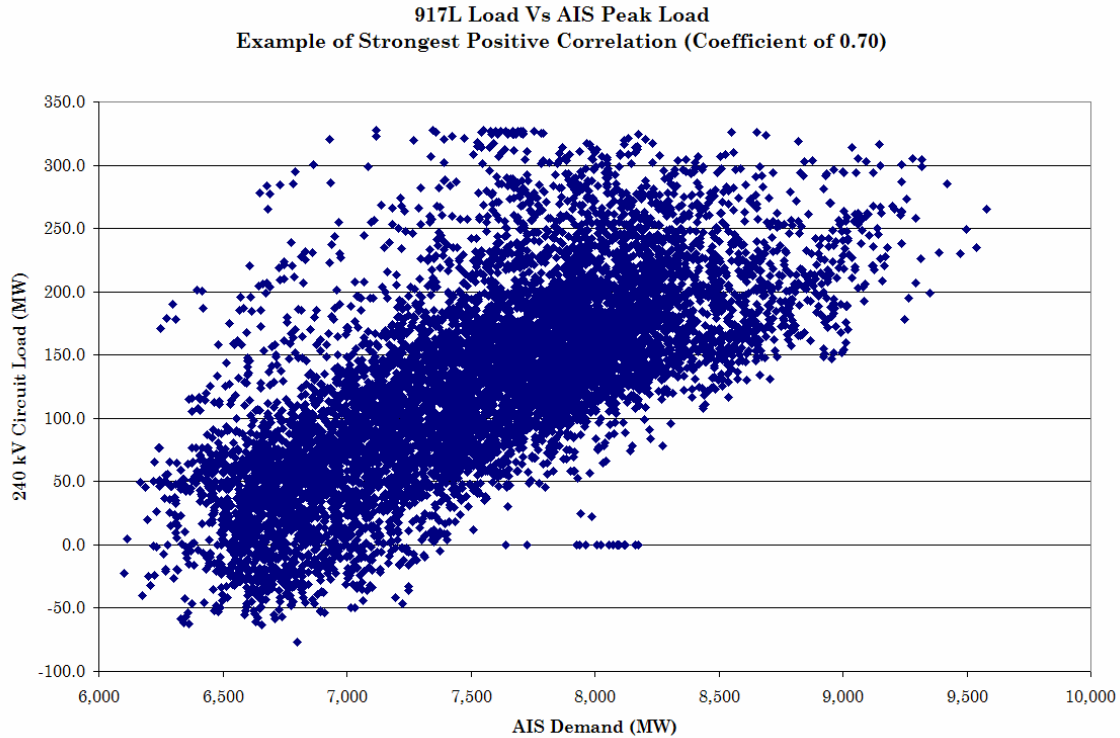

The path flow south of KEG (Keephills, Ellerslie and Genesee) was used as an example in the original Transmission Cost Causation Study to demonstrate that the Bulk System components are not always stressed at the time of the system peak load. For the path between Edmonton and Calgary, path flows exhibit an inverse correlation to the system peak load.

The actual flow on the south of KEG path for 2005 is shown in Figure 6 below, and the Pearson correlation coefficient between path flow and system load is negative 0.15. The actual flow south of KEG is measured as the sum of the loads on the six 240 kV circuits.

Figure 6 North-South Flow from Edmonton with 2005 Actual Meter Data

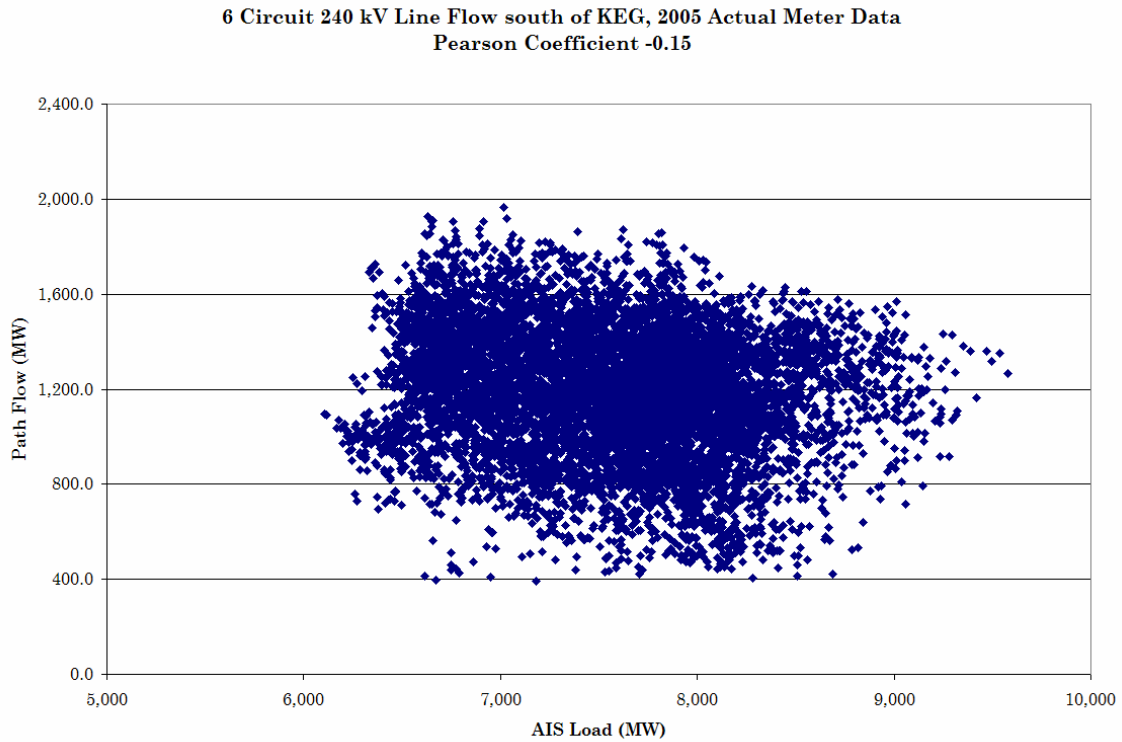

Detailed data for that path was also available on a forecast basis for 2007, as a result of its examination in the original Transmission Cost Causation Study. For the 2007 forecast data, exports were excluded to consider Alberta load only while imports were included in this scenario. The Pearson's coefficient for the south of KEG path based on 2007 forecast load was -0.13. This test suggests 2005 actual data provides conclusions similar to those that would be reached using forecast data for planning purposes.

Figure 7 The Path Flow South of KEG

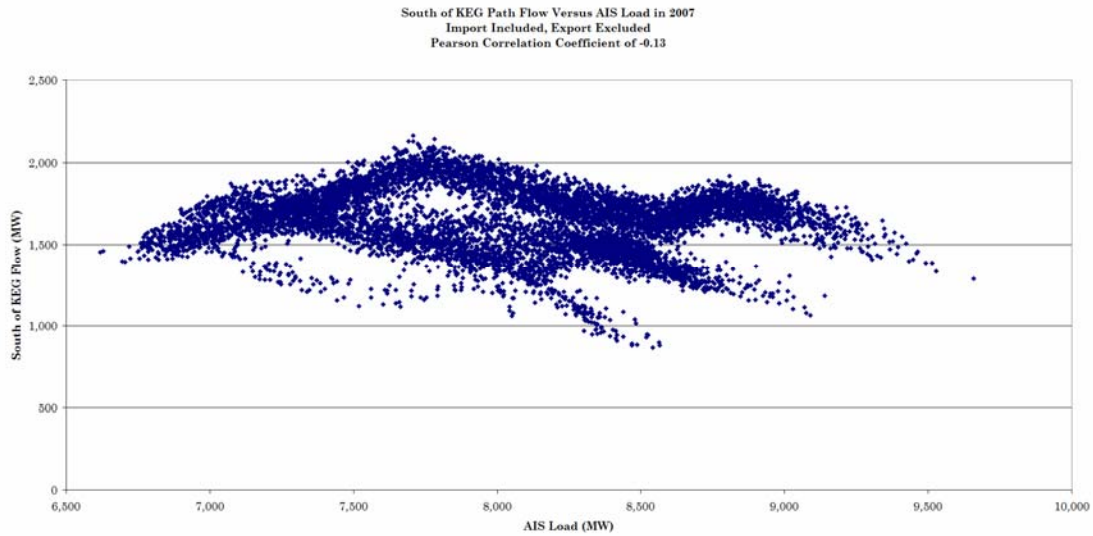

The Atco Electric circuits more frequently exhibited a positive correlation than the AltaLink circuits in southern Alberta. 76% of the Atco Electric circuits had a positive correlation coefficient while 62% of the AltaLink circuits had a positive correlation coefficient. This reinforces the planners view that in the north west part of the province, the Bulk System stress occurs at the same time the area load peaks, all of which is coincident to the peak AIL load. The following chart shows the distribution of correlation coefficients for 240 kV circuits in Alberta.

Figure 8 Occurrence of Correlation Factors by Number of 240 kV Circuits

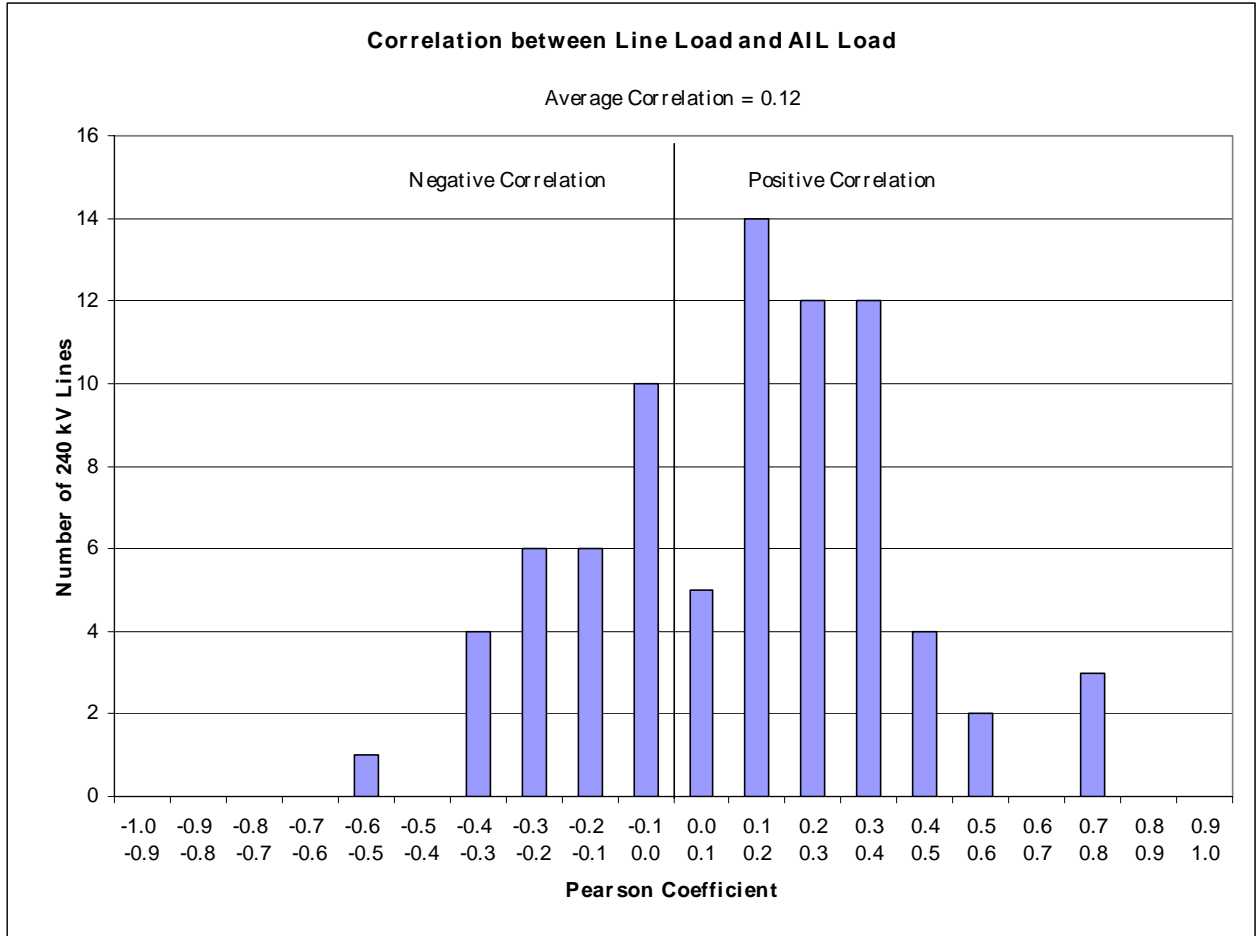

Using the number of lines as an indicator of correlation has some drawbacks because all lines are considered equal regardless of their length. Therefore, the same correlation analysis was weighted by line length to provide the following distribution. The large number of kM of line with a slightly negative correlation includes lines within the Edmonton to Calgary corridor, all of which are relatively long lines.

Figure 9 Occurrence of Correlation Factors Weighted by kM of 240 kV Circuit

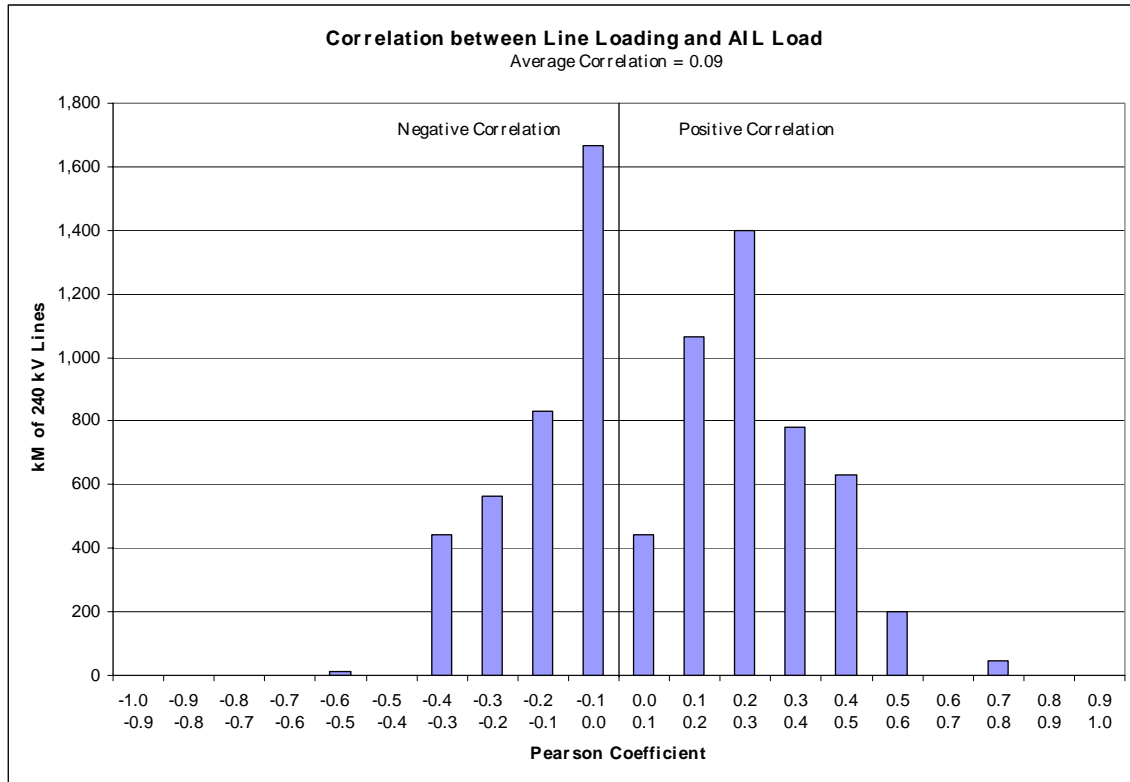
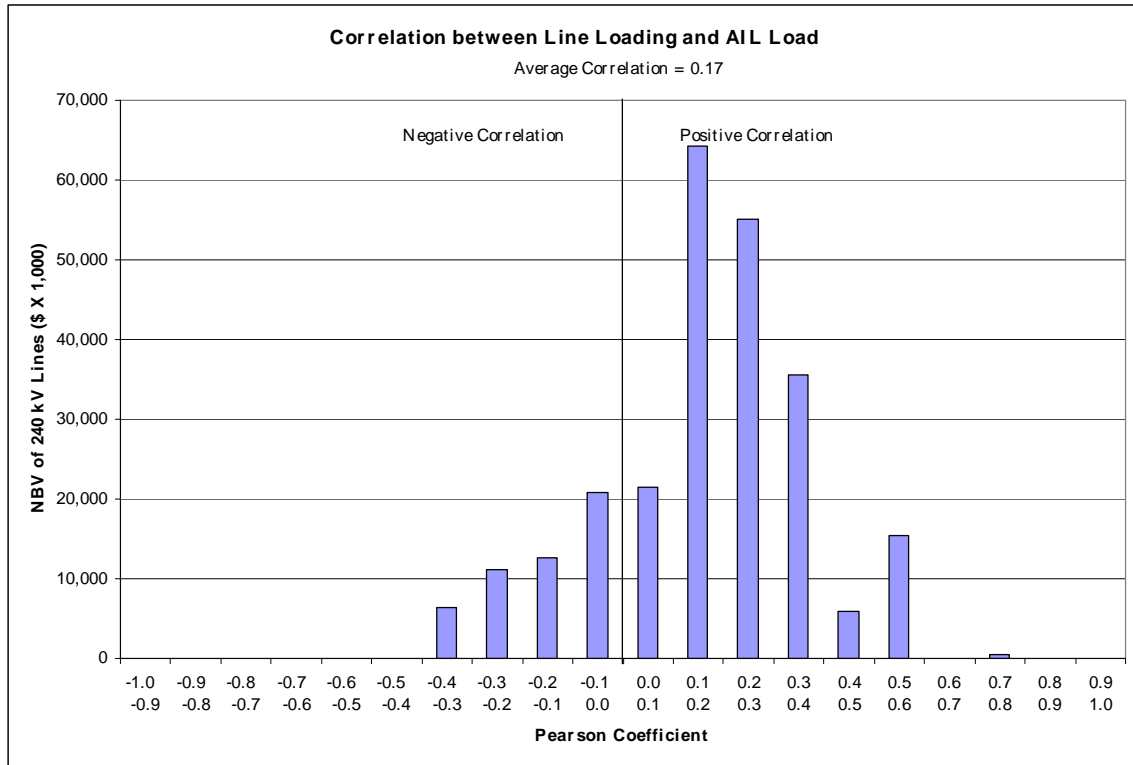

Figure 10 Occurrence of Correlation Factors Weighted by NBV of 240 kV Circuit



The same correlation analysis was weighted by NBV instead of line length to provide the following distribution. Weighting by NBV provides heavier weighting to new lines.

Weighting by NBV relates closest to the revenue requirement, while weighting by line length relates closest to overall cost causation.

2.2.4. Percent Loading based on Thermal Capacity

Correlation factors were also calculated on the basis of load divided by thermal capacity. Since the summer thermal capacity is always equal to or less than the winter capacity, and the AIL peaks in the winter, the correlation factors for thermal capacity will be lower than those of simple line loading. The following figure shows the number of lines with their respective correlation factor when analyzing the correlation between AIL load and percent of thermal capacity.

Figure 11 Occurrence of Correlation Factors by Number of 240 kV Circuits

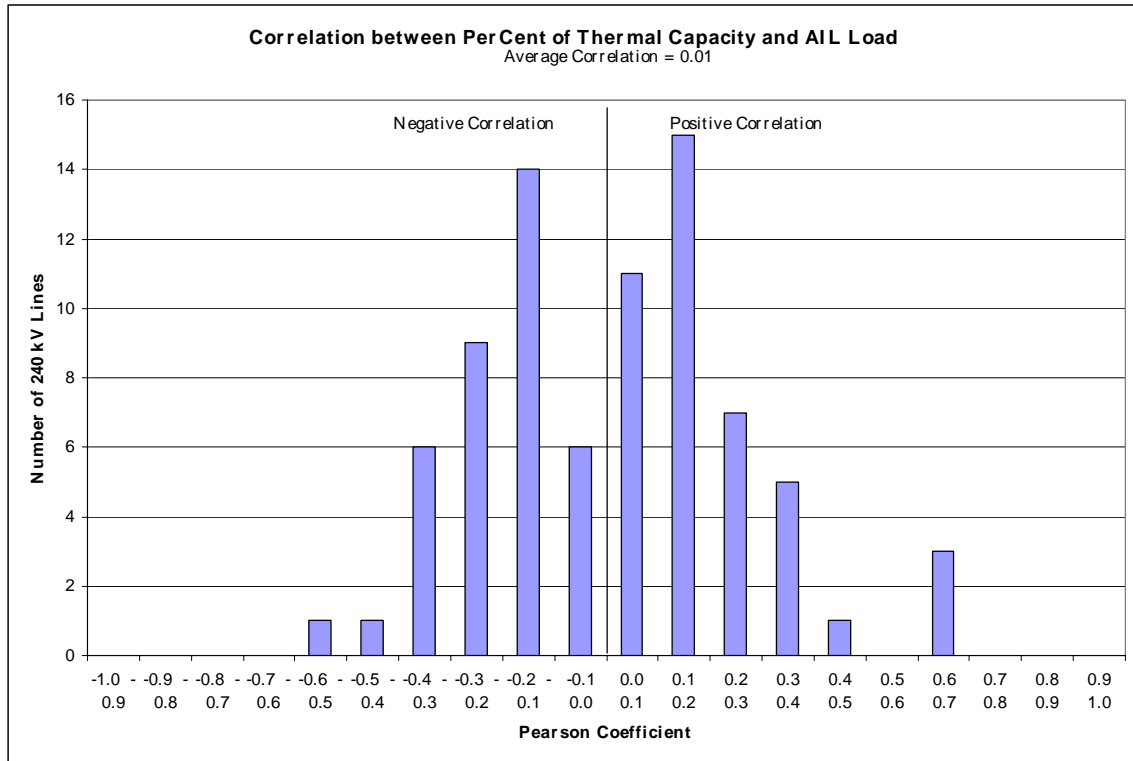

Again, using the number of lines as an indicator of correlation has some drawbacks because all lines are considered equal regardless of their length. Therefore, this correlation analysis was weighted by line length and NBV as shown in the following two figures to provide the following distribution.

Figure 12 Occurrence of Correlation Factors Weighted by kM of 240 kV Circuits

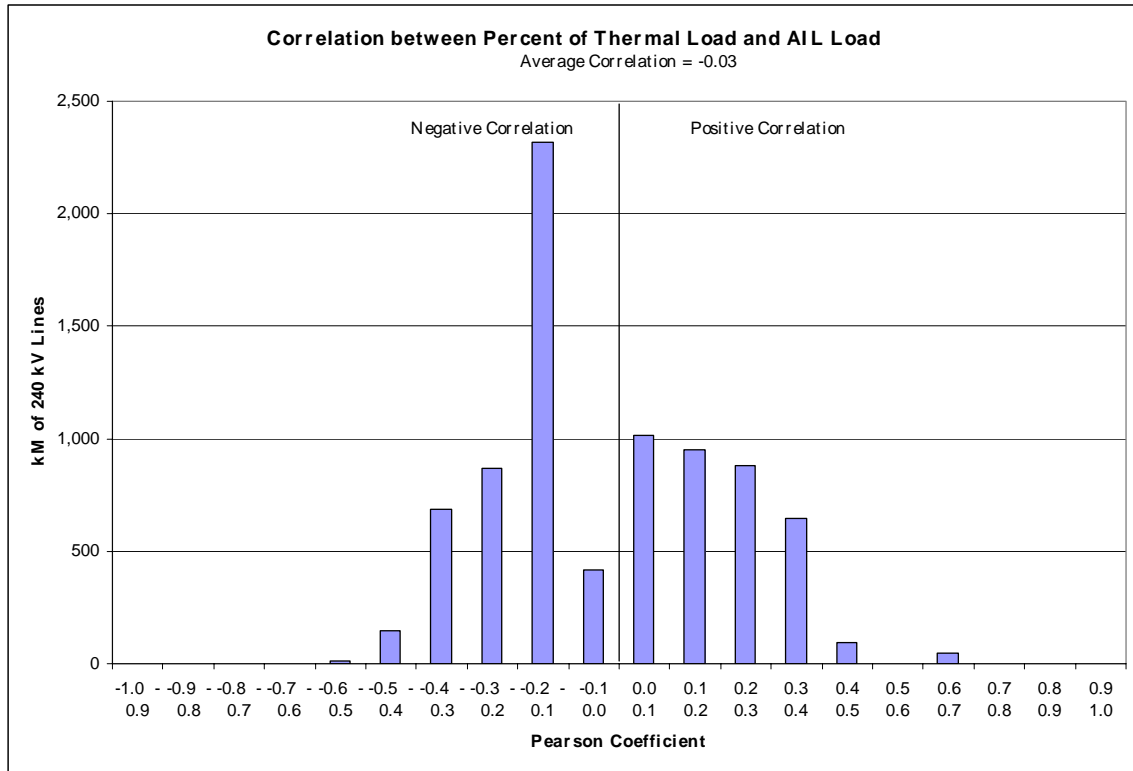
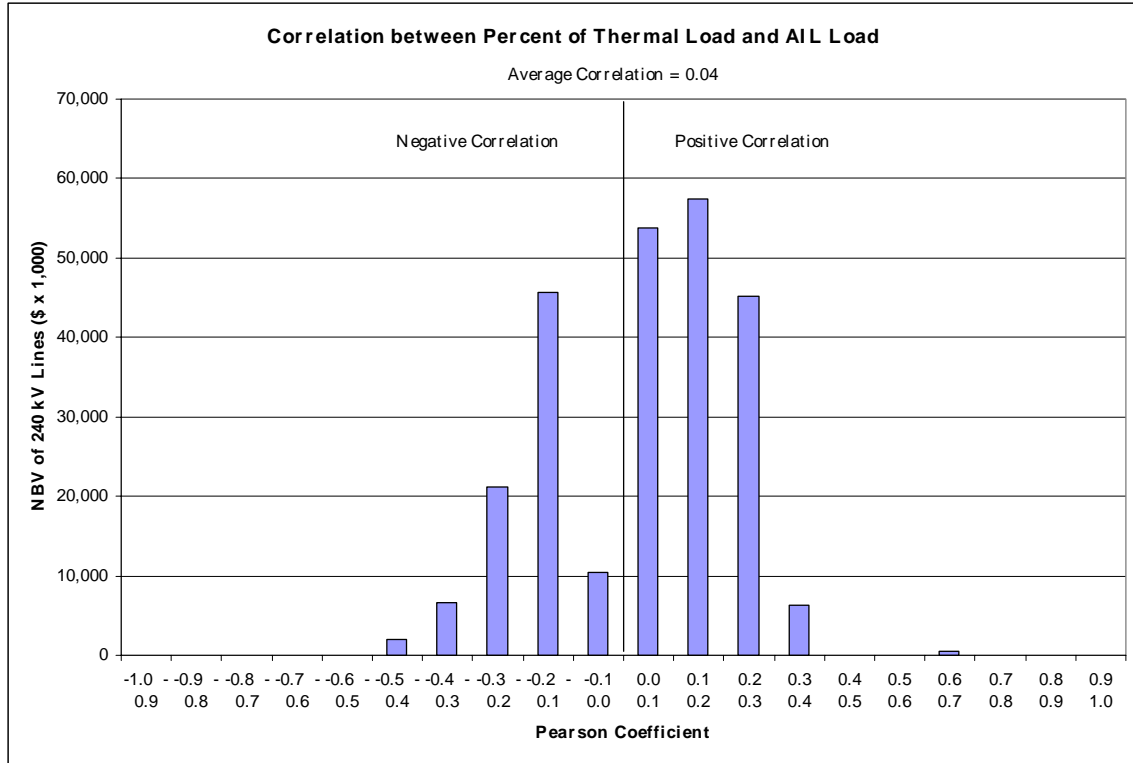

Figure 13 Occurrence of Correlation Factors Weighted by NBV of 240 kV Circuits



The following table summarizes the average correlation coefficient for each of the scenarios.

| Description | Line Loading Coefficient | Thermal Capacity Coefficient |
|-----------------------------|--------------------------|------------------------------|
| Weighted by Number of Lines | 0.12 | 0.01 |
| Weighted by Line Length | 0.09 | -0.03 |
| Weighted by Net Book Value | 0.17 | 0.04 |

Observations

The analysis finds a weak relationship between AIL peak load and the time of maximum stress on the Bulk System. Some components of the Bulk System such as the north-south lines between Edmonton and

Calgary exhibit a negative correlation where the circuit loads are highest at the time that AIL load is low.

In reviewing the hourly data, none of the 240 kV circuits experienced its annual peak load during the hour of the AIL peak load. Also, none of the 240 kV circuits experienced its monthly peak load during the hour of the monthly AIL peak load.

During the hour of AIL peak load, lines were loaded at 61% of their annual peak load on average. During the hour of AIL peak load, 4 of 79 lines were at 90% or more of their annual peak load.

This analysis was completed to find the correlation between the AIL peak load, and maximum stress on the system (using line loading, and percent of thermal capacity as proxy for maximum stress). On the basis of this analysis, the correlation between coincident peak load and stress on the Bulk System is very weak. When considering correlation factors between AIL load and circuit loading, weighted by line length, the correlation is below 10%. When weighting by NBV the correlation is below 20%.

Neither the quantitative analysis of correlation between stress and AIL load, nor the qualitative review of stressors for the bulk system identify AIL coincident peak as a factor.

2.3 Summary – Classification of Bulk System

This report was completed to study the factors that drive demand related costs of the Bulk System. Interviewing transmission planners to determine these factors completed a qualitative analysis. The factors that cause planners to upgrade the Bulk System include violations of planning criteria (indicating stress on the Bulk System) with respect to thermal capacity, voltage and stability. The time of maximum stress on the Bulk System is driven by a number of variables including the location of generation and load, the profiles (daily and seasonally) of generation and load, and the configuration of the electric transmission system in Alberta.

The following example demonstrates the potential for a Bulk System to be lightly loaded at the time of peak load, and to be stressed during light load hours. Consider an area where base load generation exceeds the load in the area. The difference must be moved out of the area with transmission lines. As shown, the maximum line loading out of the area occurs during the lightest load hours.

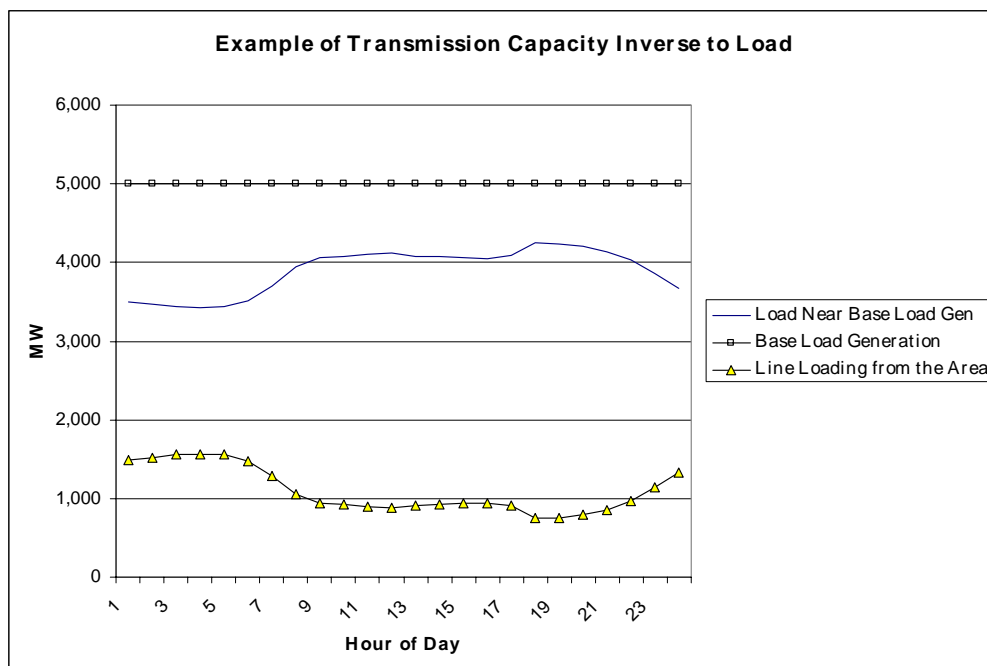

The correlation analysis was performed for the purpose of a high level test of the hypothesis that Bulk System transmission upgrade drivers are represented by coincidence to system peak load conditions. The result of the analysis is that there is very little, if any correlation between the maximum stress on the Bulk System and the AIL peak load. The maximum stress on the Bulk System is driven by a number of variables including the location of generation and load, the profiles (daily and seasonally) of generation and load, and the configuration of the electric transmission system in Alberta. As these variables change, the time at which maximum stress occurs on the Bulk System will also change.

2.3.1. Classification of Bulk System Costs

The original topic of discussion was the classification of Bulk System Costs. The Transmission Cost Causation Study identified that the majority of costs are classified as demand related costs but the demand type or timing was not fully studied because there is only one rate class. The Transmission Cost Causation Study considered that coincident load at the time of maximum stress on the Bulk System is the appropriate benchmark for the classification of bulk system costs, but noted that coincident load at the time of maximum stress is not a practical demand related billing parameter.

Based on the assessments of planners and analysis earlier in this section, it is apparent that the time of maximum stress on the Bulk System occurs at various times throughout the year, and the time of maximum stress for one part of the Bulk System does not coincide with maximum stress for other parts of the system. Different areas of the Bulk System experience maximum stress at various times during the year and by various circumstances. There is diversity among loads in Alberta, and there are factors beyond load (i.e., generation, imports, etc.)

that cause maximum stress and drive the need to expand the Bulk transmission system.

Transmission expansions in southern Alberta are driven by thermal capacity constraints in the summer, and in the future, transmission expansion in the south will be driven by the addition of wind generation. Some transmission expansions in northern Alberta are driven by load related concerns that occur in the winter and coincident to the peak Alberta load.

The TCCS identified that the Local System was designed to serve an area with a small number of points of delivery. By extension, the Bulk System is designed to serve a larger number of points of delivery. The Bulk System must be designed to meet the demand of a larger group of POD's, and in of cost causation, is designed to provide service to Local Systems which provide service to the POD's.

The coincident peak of the AIL (all POD's in the province) encompasses too much load and is not a reliable or predictable factor in cost causation on the Bulk System. Transmission system planners do not plan bulk system components in response to system peak load, but in response to conditions in an area that result in a violation of thermal capacity, voltage or stability criteria in that area of the bulk system. Allocation of costs to the coincident peak has the potential to shift loads away from the coincident peak without any corresponding reduction in the causation of costs resulting in a volatile cost allocation.

The maximum demand at each POD is a significant factor in the allocation of costs at each POD as well as the local system. At the POD, the coincident load to maximum stress is the same as the maximum demand (with compensation for thermal capacity). The further that you move from the POD to the Local System and into the Bulk System, the more diversity there is between loads and the diversity increases the

difference between coincident load to maximum stress and maximum demand. If there were no diversity, then maximum demand and coincident load to maximum stress would occur at the same time and both parameters would be appropriate to classify the demand related costs.

Since there is diversity between loads, and since the coincident load to maximum stress is not a practical means to allocate costs, the next best alternatives are to classify costs on the basis of load coincident to the AIL peak, or maximum load at each POD. Both have strengths and weaknesses. System planners model the system on the basis of loads at the time of maximum stress. If maximum stress occurs at the time of the peak system load then coincident peak load and maximum demand are equal. If maximum stress occurs at a different time, then the planners model the system on the basis of an estimate of load at the time of maximum stress that is neither AIL coincident peak load, nor maximum demand.

Given that maximum demand is known and measured by POD and is easy to understand and is less volatile than load coincident to AIL peak system load, maximum demand is a better classification of demand related costs in the Alberta transmission system at this time.

The time of maximum stress on the Bulk System is driven by a number of variables including the location of generation and load, the profiles (daily and seasonally) of generation and load, and the configuration of the electric transmission system in Alberta. The time of maximum stress on the Bulk system cannot be reliably predicted by considering the peak system load in Alberta. The maximum demand at each POD is an appropriate indicator of contribution to stress on the Bulk System. When there is a shift in location and production profiles for generation, or there is a shift in location and profiles of load, the classification of

demand related costs should be reassessed to determine the most appropriate measure.

3. INTERPROVINCIAL TIES

The interprovincial interconnections were built under the vertically integrated electric utility industry. The interprovincial ties were built on the basis of generation reserve sharing. With the construction of the tie line, Alberta and BC could rely on each other, thereby reducing the amount of generation reserve required to provide reliable electric service.

The Alberta BC Interconnection was commissioned in 1986, and was justified on the basis that the tie line was the equivalent of building 300 MW of peaking generation in Alberta to provide reliable service. The BC tie is a 500 kV AC tie line which has a thermal capacity in excess of 1,000 MW. The available transfer capacity is normally limited by voltage in southern Alberta. The export limit for the first five months of 2006 has typically been between 0 MW and 700 MW and has averaged 50 MW. The import limit for the same time period has typically been between 0 MW and 700 MW and has averaged 625 MW.

The Alberta Saskatchewan Interconnection was built in the late 1980's and is an asynchronous back-to-back DC link. The thermal capacity of the interconnection is 150 MW. Voltage limits and thermal capacity constrain the available transfer capacity of this interconnection. The export limit for the first five months of 2006 has ranged from 0 to 60 MW with an average of 30 MW. The import limit has ranged from 0 to 153 MW with an average of 150 MW.

While the interprovincial interconnections were built to provide "generation reserves" in a vertically integrated utility structure, since deregulation of the utility industry the interconnections have been used primarily for economic transactions on an opportunity basis (although a non-opportunity export rate is being proposed in the AESO's 2007 tariff application).

3.1 NBV of Interprovincial Interconnections

The net book value of the provincial interconnections is based on the value of the Langdon Substation and the 500 kV transmission line from Langdon to BC for the BC interconnection, and the transmission line from Empress to Saskatchewan (138 kV 830L), the McNeil converter station, and the Sask Border Tie for the Saskatchewan interconnection.

The NBV of these facilities is \$115 million (2003) and transmission NBV for the four largest TFO's was \$1,456 million. The TCCS identified that 46.1% of the total NBV was associated with Bulk System facilities.

Therefore, the Bulk System including interprovincial ties had a NBV of \$672 million.

The interprovincial ties comprise of 17% of the NBV of the Bulk System.

3.2 Summary

The TCCS determined there were three functions of a transmission system, and that interprovincial interconnections fall within the function of the Bulk System.

The Bulk System was defined as the system that delivers bulk electric energy (large volume) over a long distance to a number of users and this definition best describes interprovincial interconnections in the old and existing industry structures.

The cost of the interprovincial ties should continue to be part of the Bulk System pending a review of a rate or rate class for long term firm imports/exports.

4. LOCAL SYSTEM

The TCCS defined the Local System as follows: The Local System delivers electric energy from the Bulk System to a local area a small number of points of delivery. The Local transmission System is commonly understood to be the underlying transmission system that provides service to local points of delivery. The Local System is normally designed with two or more transmission circuits to each point of delivery or radial connection, such that continuous service can be provided in the event of an outage on one of the circuits. The Local System does not include radial transmission lines. An example of transmission facilities included in the Local System is the 138 kV lines within the City of Calgary.

With this definition, the Local System should include part of substations which are served by multiple transmission lines (“networked”). The part of the networked substation included in the Local System would be the switches, circuit breakers and bus work on the high voltage side of the transformers. The original TCCS defined the Point of Delivery (POD) as follows: The point of delivery includes all facilities that provide service at one point of delivery substation, including a radial transmission line used exclusively by the point of delivery substation. The point of delivery facilities normally provides service to one customer (a distribution utility, or a transmission connected industrial customer).

The purpose of the distinction between local system and point of delivery was to allow the study of cost causation for facilities sized to meet the needs of an individual customer at the POD versus the cost causation for facilities sized to meet the needs of several customers.

The original TCCS study did not include the distinction of networked substation high-side facilities, because the TFO cost

data did not provide enough detail to separate the cost of these facilities.

In order to study the relationship between the Local and POD costs within a networked substation, more detailed cost information is required. The 2003 cost data do not provide sufficient information to separate substation costs into Local System and POD related costs. However, 34% of POD's are radially fed while 66% of the POD's have more than one source line and would be networked. The impact of this distinction on the Local System and POD is therefore reduced.

Figure 14 Local System Components of a Single Transformer Substation

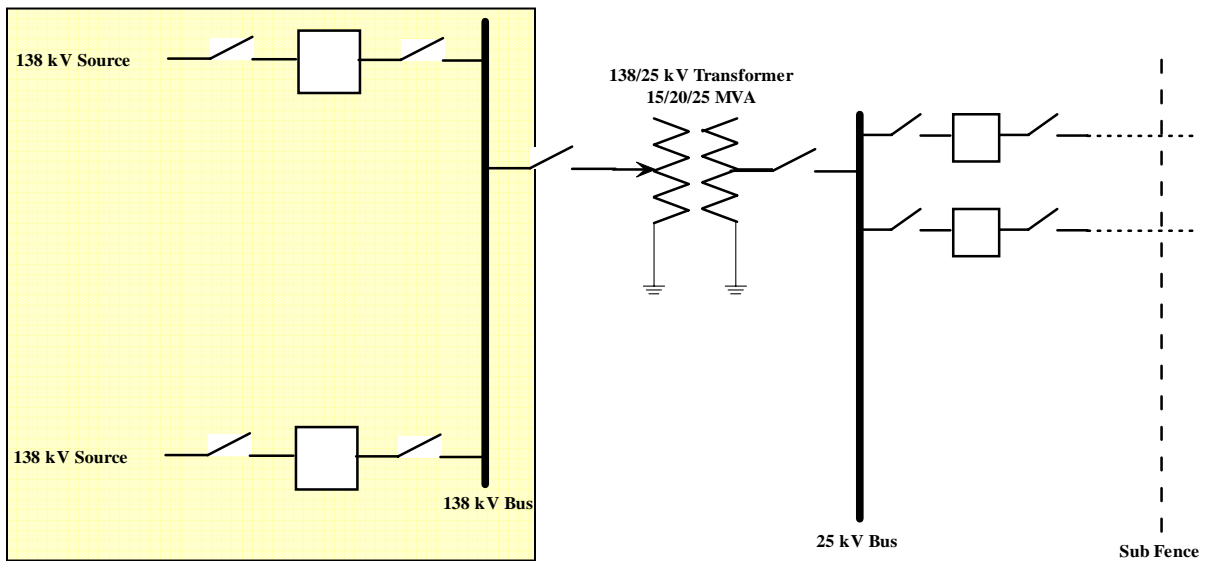
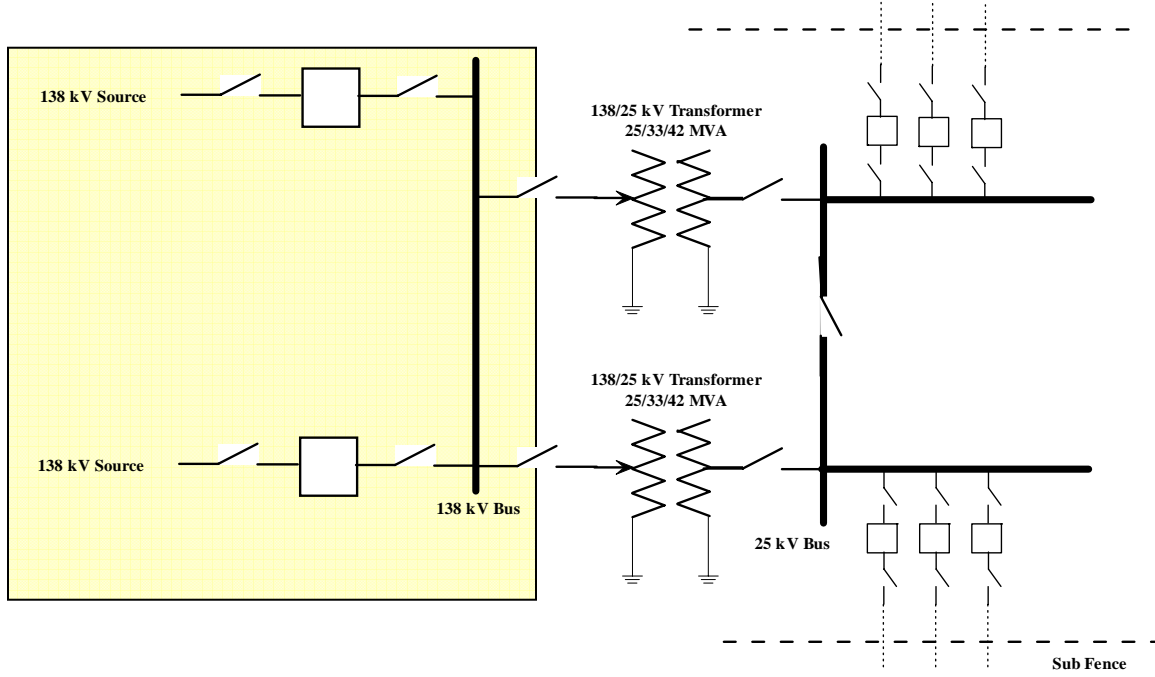

Figure 15 Local System Components of a Double Transformer Substation



4.1 Alignment With Contribution Policy

The definitions of Local System and POD related costs relate to the functionalization of the transmission system. The definitions associated with the Customer Contribution Policy (i.e. customer-related and system-related facilities) are used to assess costs when connecting new customers to the system.

Customer related facilities are those facilities that must be built to interconnect a new customer. While these facilities may only serve one customer at the time of construction, these facilities may at some point be used to serve other customers, and may be included in more than just the POD function. The cost of customer related facilities, and the Contribution Policy are important to new and existing customers because they determine how much a new customer must pay, and how much existing customers must pay when a new customer is connected to the system. The proper determination of the cost of customer related facilities helps ensure equitable recover of costs between new and existing customers. Generally, customer related facilities are similar to the POD function.

The purpose of defining functions of the transmission system is for producing a cost study with respect to the embedded costs of the system. This ensures that all customers are allocated costs of the transmission system proportional to their use of the system to ensure equity between customers.

The TCCS functional definitions and Customer Contribution Policy definitions do not align perfectly because they have different purposes.

Substation facilities to accommodate a new customer would be considered customer-related under the AESO's contribution policy, but could involve a networked substation that includes both POD and Local facilities as per the functional definition discussed above.

Alignment of functional definitions with existing Customer Contribution definitions may involve trades offs in accuracy between either which costs are functionalization as POD or which costs are determined to be customer-related in a contribution calculation.

4.2 Conclusion

The cost data from the TFO's does not provide sufficient breakdown to study transmission costs with the refined functionalization definitions discussed above. The costs data does align with the definition of customer-related costs in the AESO's Customer Contribution Policy. It is not expected that additional data detail to allow a precise assessment of the impact will be available in the near future.

Based on the data currently available, the expected small impact of the refinement, and the resulting misalignment between functionalization and cost treatment in the contribution policy, it seems appropriate to continue the functionalization proposed in the TCCS.

5. POD COSTS

The TCCS studied the cost of POD substations owned by AltaLink and Atco Electric. The study found that 56% of POD substation costs were fixed, and that 44% of the costs varied with demand on the basis of a zero intercept study.

The cost of POD's (TFO substation and radial line cost data) in relation to capacity exhibits variation because the TFO data does not separate out the Local System as defined in the preceding section, and the cost data is NBV. All of these factors will diminish the relationship between capacity and cost. Older points of delivery will exhibit low NBV, as will points of delivery that have CIAC accounted for against the cost of the points of delivery. Points of delivery that include more line costs or high side equipment will experience higher costs.

The NBV costs data provided by the TFO's does not have sufficient data to further break down these costs.

The AESO has studied recent projects where additional cost detail is available as part of its contribution policy study. The AESO study has found that on the basis of new PODs, somewhat more than half the costs are customer related, and somewhat less than half the costs are demand related which is consistent with the findings of the TCCS study based on embedded costs. PS Technologies therefore understands the AESO will rely on the contribution policy study data for additional analysis of POD costs.

6. CONTRIBUTIONS IN AID OF CONSTRUCTION (CIAC)

This section of the update reviews the alignment of CIAC with functions in the TCCS Study (Bulk, Local and POD).

Atco Electric was able to correlate CIAC by facility and provided the data on a facility-by-facility basis. Therefore, CIAC was functionalized in the same manner as the facility that was constructed when the CIAC was collected. CIAC offset the NBV of transmission system facilities in all of the functions including POD, Local and Bulk System facilities. The Bulk System facilities that were offset with CIAC include 240 kV lines, POS substations and Dual Use substations.

AltaLink did not track CIAC by facility, and all of the NBV's for AltaLink facilities were based on original cost less accumulated depreciation.

CIAC was treated as a separate account in the case of AltaLink.

AltaLink's CIAC was reviewed and assessed as 22% being related to STS service, and 78% being related to DTS service. The STS amount offsets POS property in the Bulk System, while the DTS amount offsets property in the POD function. AltaLink's CIAC amount has therefore been functionalized to more accurately reflect the appropriate functionalization. CIAC amounts to less than 4% of AltaLink rate base in 2003, and therefore additional refinement has limited impact.

The functionalization shown below has been adjusted to reflect this refinement to CIAC treatment.

TCCS Functionalization of Alberta's Transmission System

| Based on % NBV Property | Bulk System | Local System | POD |
|-------------------------|-------------|--------------|-------|
| Functionalization | 45.7% | 15.7% | 38.6% |

Translation into 2002/03 NBV

| Based on % NBV Property | Bulk System | Local System | POD |
|-------------------------|-------------|--------------|---------|
| Functionalization | 677,560 | 232,841 | 571,508 |

Offset of CIAC for AltaLink Facilities

| Based on % NBV Property | Bulk System | Local System | POD |
|-------------------------|-------------|--------------|--------|
| Functionalization | 5,771 | 0 | 20,463 |

NBV with compensation for AltaLink CIAC

| Based on % NBV Property | Bulk System | Local System | POD |
|-------------------------|-------------|--------------|---------|
| Functionalization | 671,789 | 232,841 | 551,046 |

Updated Functionalization of Alberta's Transmission System - 2002

| Based on % NBV Property | Bulk System | Local System | POD |
|-------------------------|-------------|--------------|-------|
| Functionalization | 46.1% | 16.0% | 37.9% |

7. DUAL USE SUBSTATIONS

The cost of Dual Use substations as treated in the original TCCS was reviewed on a case by case basis. When a substation was originally built to serve load, and a generator was later connected to the substation, the cost was functionalized as a POD substation. When a substation was built to interconnect a generator(s), the cost of the substation was functionalized as POS and therefore as a Bulk System. All of the substations interconnecting the generators that existed prior to 1996 were functionalized as POS and as Bulk System.

Substation fractions as implemented in the AESO's final 2006 tariff were not used in the TCCS Study and substations were functionalized on the basis of their original purpose as discussed above.

The cost data for the TCCS Study was based on 2002/2003 data and does not include all of the Dual Use substations that exist today. The Dual Use substations that provide service to the generators that were in existence prior to 1996 were functionalized as Bulk System. The newer Dual Use substations were functionalized as either POD or POS depending on the original purpose of the substation (if the substation was originally constructed to serve load, it was functionalized as POD, and if the substation was built to accommodate new generation, it was functionalized as POS/Bulk. Substations that are owned by generators are not included and do not appear in the TFO list of facilities.

The following chart shows the NBV of substations versus the DTS contract level.

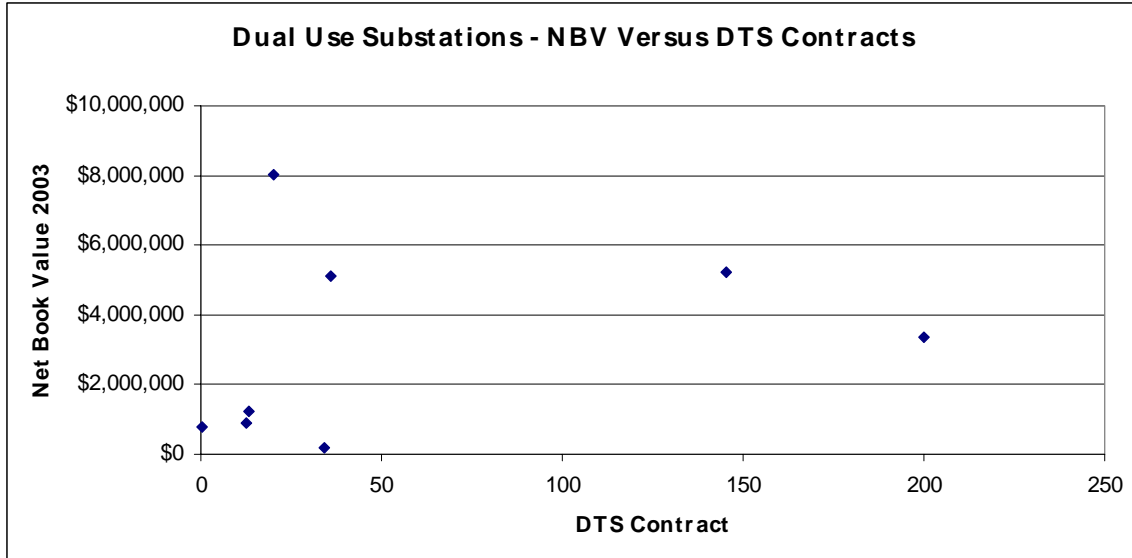

The correlation between NBV and load is weak. Dual use substations will provide a challenge for correlation because some substations were sized to serve the load with little or no regard for generator size, while other substations were sized to accommodate the generator with little or no regard for the load while other substations have DTS and STS load/supply of similar magnitude.

The chart showing the NBV multiplied by the DTS Substation Fraction versus the DTS contract is shown below.

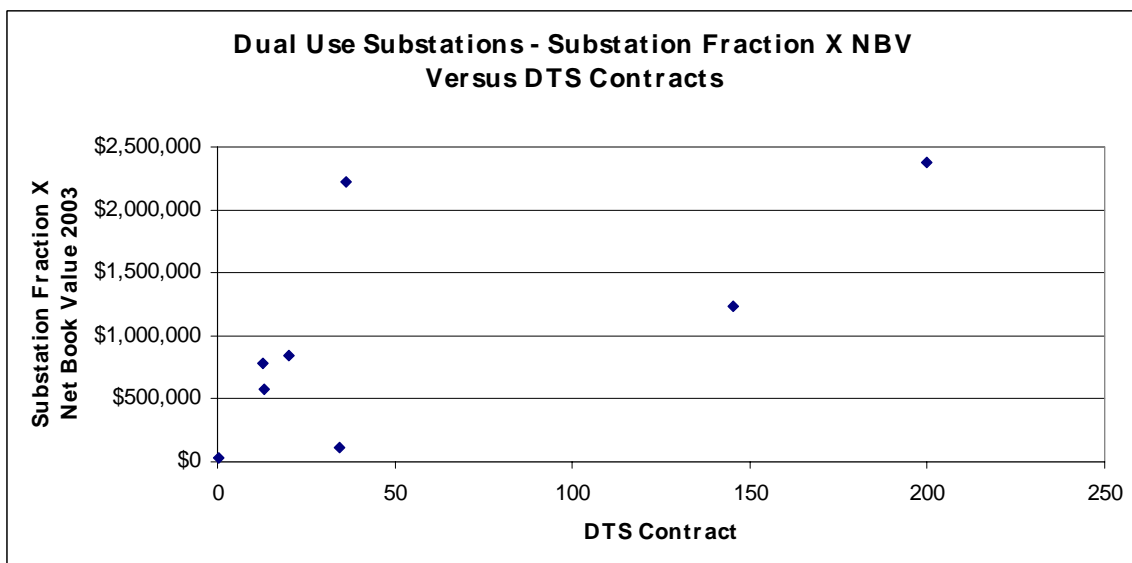

The relationship between cost and size of Dual Use facilities does not bear and strong relationship when considering embedded costs. The cost of generators that existed prior to 1996 were not included in these charts because these facilities are generally very old in relation to plant built in the last 10 years. The different vintages of facilities is one factor that distorts the relationship between cost and DTS contract capacity.

The functionalization of point of exchange costs between dual-use load and supply customers cannot be determined through analysis of the cost data. Costs will always need to be shared between the two functions. In the AESO's case, the EUB has approved cost sharing based on the substation fraction approach.

8. OPERATIONS, MAINTENANCE AND ADMINISTRATION

The TCCS study was based on the assumption that OM&A costs were proportional to property. This assumption was made because OM&A costs are a small part of the total revenue requirement, and detailed data was unavailable. OM&A accounts for approximately 25% to 33% of the total revenue requirement for a TFO.

One concern of interveners is that some facilities are older than others, and that OM&A should be studied to reflect the vintages that exist. A high level review of depreciation studies shows that substation facilities and transmission facilities have a similar remaining composite life. Based on similar remaining composite lives, it is not apparent that some facilities would have significantly different levels of OM&A costs associated with their operation.

TFO GTA's contain some information regarding the components of OM&A and additional detail from TFO's would be required to functionalize OM&A costs in alignment with the functional definitions in use in the TCCS Study. Additional study would be required to determine the OM&A of facilities as they age. Conventional wisdom indicates that OM&A costs increase as facilities age and this relationship for facilities in Alberta must be understood to properly functionalize these costs.

The OM&A costs were not studied because work was focused in other areas such as classification of Bulk System costs. A study of OM&A costs must ensure that functionalization of OM&A costs is aligned with the functions in the cost study, and that the current distinction between Local System and POD system may change.

OM&A costs may vary by vintage, whereby old facilities require more funds to maintain than do newer facilities. OM&A costs may also vary by equipment type, whereby substation equipment requires a different types of maintenance than do transmission lines (vegetation management is

required only for lines while switch and tap changer maintenance applies only to substations).

The breakdown of AltaLink and Atco Electric TFO facilities show there is a different make up of substation equipment versus line equipment by function as follows:

| | Bulk | Local | POD |
|------------|--------|--------|--------|
| Substation | 43.6% | 10.8% | 90.9% |
| Line | 53.4% | 86.6% | 5.8% |
| General | 3.0% | 2.5% | 3.3% |
| Total | 100.0% | 100.0% | 100.0% |

The relative age of equipment is estimated by dividing the accumulated depreciation by the property, plant and equipment amount. The AltaLink data for 2003 shows that both transmission lines and substations have accumulated depreciation of between 50% and 60%, indicating that the relative ages are similar.

| | 2003 PPE | 2003 Acc Dep | Acc Dep % of PPE |
|-------------|-------------|-----------------|---------------------|
| Substations | 659.7 | 343.5 | 52.1% |
| Lines | 657.3 | 388.4 | 59.1% |

At this time, there is insufficient data to properly allocate OM&A costs by function, vintage or equipment type.

The impact of functionalizing OM&A is likely to be small because:

- OM&A accounts for about ¼ of the revenue requirement,
- Difference in OM&A accounting for equipment age is likely to be small because all equipment is similarly aged,
- Difference in OM&A accounting for difference between substations and lines is likely to be small since the largest function (Bulk System) is relatively equally split by line and substation equipment.

9. RECOMMENDED ADDITIONAL ACTIVITIES

Local System and POD

Further study regarding the distinction between Local System and POD should be completed following the review of the Customer Contribution Policy.

The TCCS study proposed a distinction between Local System and POD that aligns with the concept of common facilities (useful to more than one point of delivery) and dedicated facilities (dedicated to one point of delivery). The Customer Contribution Policy uses different distinctions.

After development of aligned definitions, the TCCS should be reviewed with functions that align to the Customer Contribution Policy. This updated study would provide a stronger basis for the fixed and demand related costs associated with POD's.

OM&A

A new study of OM&A should be conducted to facilitate the functionalization of OM&A. The relationship between age and OM&A should be studied as well as the relationship between OM&A and equipment type. This study would provide for an improvement in the functionalization of approximately $\frac{1}{4}$ of the transmission revenue requirement.

The data required for such a study is not currently available. The development and compilation of this data would require a considerable effort and would require detailed O&M expenditures by facility and by equipment type over the life cycle of transmission and substation equipment. Since OM&A accounts for a small portion of the total revenue requirement, better functionalization of OM&A may not change the results of the TCCS study significantly.

10.

APPE

NDIX A

Transmission Cost Causation Study Activities

Based on the EUB direction, stakeholder comments, and background information provided in the preceding section, the AESO proposes that the *2006 Cost Causation Study* include the following eight activities.

1. **Bulk System** — Study all of the major bulk paths (between 20 and 30 paths) to determine the relationship between the time of maximum stress and the time of peak system load. Review the functionalization of bulk system and local system to ensure continuing consistency with AESO planning. This study component would primarily use technical data from the 500 kV N-S Need Application as the basis, as well as additional data from more recent planning studies prepared by the AESO, if necessary.
2. **Interties** — Review the treatment of intertie facilities (the Alberta-BC and Alberta-Saskatchewan interconnections) in the *2006 Cost Causation Study*, including the context of this treatment under current legislation and regulation. If appropriate, study and recommend a means to separate the costs of intertie facilities from domestic facilities within Alberta. This study component would utilize the 2003 cost data used in the original study.
3. **Local System and POD** — Study and recommend a means to better differentiate between the Local System and POD functions. Ensure definitions align with usage elsewhere in the AESO tariff (specifically, within the terms and conditions of service). This study component would utilize the 2003 cost data used in the original study.
4. **POD** — Study POD costs in more detail, including more detailed analysis of POD cost components, how POD costs vary with load size, and whether such variation is linear or follows some other pattern. This study component would utilize the 2003 cost data used in the original study. As well, this study component would be coordinated with, and potentially use additional detailed data from, the investment level study being conducted as part of the AESO's 2007 terms and conditions consultation.
5. **Contributions** — Enhance the *2006 Cost Causation Study* by more precisely including the effect of contributions in aid of construction. Study the alignment of contributions with bulk system, local system, and POD functions, and develop a methodology to align and correlate contributions with facilities. This study component would primarily utilize the 2003 cost data used in the original study.
6. **Dual-Use Substations** — Review costs associated with transmission service at dual-use substations in the context of the AESO's 2006 rate structure (including the use of

substation fractions), to ensure alignment between the POD charge in the DTS rate and the Primary Service Credit. For each of the 18 dual-use substations (excluding Fort Nelson) identified in section 4.10 of the AESO's 2006 GTA, assess the costs, revenues, ownership, contributions, contract levels (DTS and STS), and any other relevant factors affecting the incurring and recovery of costs by the AESO. Propose a mechanism to fairly recover costs at dual-use substations.

7. **Operations, Maintenance, and Administration** — Enhance the *2006 Cost Causation Study* by studying operations, maintenance, and administration costs and causation relationships to determine if these costs should be functionalized and classified in the same manner as TFO capital-related costs. If appropriate, use the results of the study to revise the functionalization and classification of such TFO costs. This study component would primarily use additional information from TFO tariff applications.
8. **Recommended Additional Activities** — Include recommendations for future enhancements of the *2006 Cost Causation Study*, based on review of the comments made by stakeholders in the AESO's 2005-2006 GTA proceeding, on input from stakeholders during the 2007 rate consultation, and on results of the activities listed above. Future enhancements may include:
 - assessing whether customers were responding to the price signals given by the DTS rate, and, if so, how and in what manner those responses were affecting transmission system planning, and
 - differentiating depreciation and return by vintage of assets (also referred to as “normalizing” data for vintage).Assess whether it is worthwhile and appropriate to complete these enhancements and, if so, propose a schedule for addressing them in a future study or tariff application.

The AESO expects that the *2006 Cost Causation Study* will primarily rely on the 2003 cost data utilized for the original *Transmission Cost Causation Study*. The AESO notes that the analysis in the study results in percentages of property by function and classification, and such percentages would not be expected to vary materially over a one or two year period.

The AESO also notes that separate consultation is being conducted on 2007 terms and conditions, import and export tariffs, and merchant interconnection tariffs. Although the rates to be included in the AESO's 2007 tariff application must align with and complement those other components of the tariff, the *2006 Cost Causation Study* refinements will focus solely on rates matters.

The *2006 Cost Causation Study* activities will be conducted from February to April of 2006. A status report included preliminary results (where available) will be provided at the end of March, and final results at the end of April. Stakeholders will be invited to comment on the preliminary and final results, and responses to stakeholder comments will be incorporated into the final report for the study, where appropriate.