

Information Document

Wind Power Forecasting

ID# 2011-007R



Information documents are for information purposes only and are intended to provide guidance. In the event of any discrepancy between the Information document and the related Authoritative Document(s) in effect, the Authoritative document(s) governs. Please submit any questions or comments regarding this Information Document to InformationDocuments@AESO.ca.

1 Purpose

This information document supports ISO rules 502.1, [Wind Aggregated Generating Facilities Technical Requirements](#) for wind power forecasting requirements.

This information document describes:

- (1) An overview of wind power forecasting;
- (2) The data transfer process;
- (3) The data transfer technical specifications;
- (4) The message formats, and
- (5) The on – ramping instructions

Please submit any comments on this information document to:

informationdocuments@aeso.ca

2 Overview of Wind Power Forecasting

2.1 Introduction

This Information Document focuses on the wind aggregated generating facility data required for wind forecasting services to support the AESO's centralized wind forecasting program, and applies only to those facilities.

The cited ISO rules in effect require that a wind aggregated generating facility transmit data to the AESO. The following is an illustration of how that requirement is to be carried out in practise:

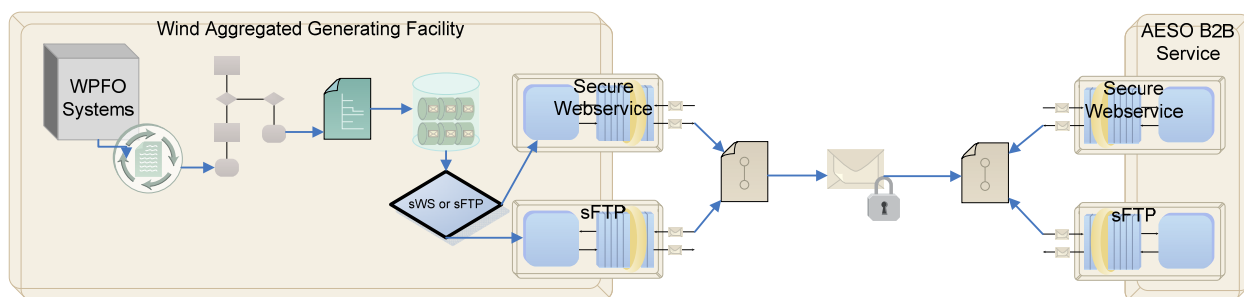

2.2 Terminology

Below is a list of terms and definitions used in this Information Document. For any additional formally defined terms and conditions please consult the [AD Consolidated Glossary](#).

“AESO B2B Service” means the external AESO Service responsible for the secure electronic movement of data between wind aggregated generating facility operators, the Forecaster and the AESO.

“Centralized Forecast Service” means the entire program of forecasting wind power in real-time and day-ahead for wind aggregated generating facilities in Alberta, using a centralized approach of collecting the data and predicting output for all plants. The AESO has contracted with a forecast vendor to produce all of the forecasts.

“Computer System” means any or all such systems employed by the wind aggregated generating facility operator, AESO or the Forecaster for the distinct purpose of transmitting meteorological, power and facility data.

“Data Communications Interface” means the physical communication channels employed by the wind aggregated generating facility operator to transmit meteorological data over the Internet to the AESO.

“Data Transfer Process” means the entire process of measuring, collecting, storing, and transmitting of meteorological data, including the Computer Systems, Forecast Data and Data Communications Interface.

“Facility Data” means all data as described in section 3.4.4. of this Information Document.

“Forecast” means the Wind Power Forecast and the Weather Forecast.

“Forecaster” means Weprog ApS (GmbH, Ltd.).

“Forecasting Application” means the proprietary software developed and used by the Forecaster to produce Forecasts.

“Historical Data” means the numerical data collected by the AESO consisting of up to 2 years’ of Meteorological Data, from wind aggregated generating facility connected to the interconnected electric system on or prior to the initial date of this Information Document.

“Meteorological Data” means all data as described in section 3.4.2 of this guide.

“MC” means the maximum capability rating for an aggregated generating facility as displayed on the Current Supply Demand report on <http://ets.aeso.ca>

“Near Real Time” means within 15 seconds of real-time actual data production.

“Power Data” means all data as described in section 3.4.3 of this Information Document.

“Secure Web-Interface” means an internet-based human interface that is secured by requiring the user to enter a password for access.

“Time Stamp” means a string of numerical data that indicates the time at which a set of Input Data was collected including the year, month, day, hour and second.

“Turbine Availability” used for planned or unplanned outages to indicate temporarily reduced Maximum Capacity (in MW) for a Wind Aggregated Generating Facility. In normal operations, TA = MC

“Web Service Interface” means the point in the Forecasting System that receives Input Data.

“Wind Power Forecast” means the prediction, based upon the use of a Forecasting Method, of the amount of power in MW that could be generated by wind energy at a specific time by a specific aggregated generating facility (an “Individual Forecast”) and at a specific time by all of the operating Wind Power Facilities combined (the “Aggregate Forecast”).

In this Information Document, the ISO may refer to wind aggregated generating facilities as a “facility”.

3 Wind Data Transfer Process

This section presents the Data Transfer Process for wind aggregated generating facilities.

3.1 Aggregated Generating Facilities Responsibility

Each of the wind aggregated generating facilities is responsible for the cost assumed with purchase, installation, and appropriate maintenance of all equipment involved with the Data Transfer Process.

Each facility is expected to monitor and control its computer systems and data communications interfaces.

Each facility is expected to transmit data according to the specification as defined in Appendix A – Data Transfer Technical Specification of this guide.

3.2 Availability

The Data Transfer Process is designed to operate fifty two weeks a year, seven (7) days a week and twenty four (24) hours each day.

3.3 Data Transfer Technical Specification

Please see Appendix A for details of the data transfer technical specification for wind aggregated generating facilities. It is recommended that all such facilities use Secure File Transfer Protocol for transfer of data. The backup solution for data transfer is Secure Web services.

3.4 Wind Aggregated Generating Facility Data

This section describes the detailed data elements that the wind aggregated generating facilities need to provide. The data are Meteorological, Power and individual facility specific data.

3.4.1 XML Document / Schema Representation / Zip File Transfer

The standard protocol for submitting data is “XML” documents, based on the schemas outlined later in this Information Document. All dates, times, and date/times shall be in ISO 8601 format. All dates, times and date/times shall be in UTC time zone. For example, 2008-01-31, 23:19:22Z, and 2008-12-01T11:32:23Z. XML Document file names will be transmitted with the following internal file name structure:

{EncodedFacilityId}_{Type}_{dateTimes}_{PositionID}.xml {dateTimes} being the time of transmission in this instance.

{TYPE} being constrained to MET (Meteorological), PWR (Power) and FAC (Facility)

Note: Understanding that facility data does not have a PositionID in the data, in its absence facility data will use the Position ID of when it is transferred.

Example: EncodedFacilityId_MET_2008_12_01T11_32_23Z_1.xml (underscores will replace colons for Windows file system issues). This will also ensure that all internal files are unique and current as well as historical data, if required can be transmitted.

The aggregation of the internal files will be transferred in a zip file. Contained within the zipped file will be measurement data consisting of MET, PWR and FAC data, as specified in section 3.4.2, 3.4.3 and 3.4.4. An example of the files and extensions that will be included in the zipped file are:

EncodedFacilityId_MET_2008_12_01T11_32_23Z_1.xml

EncodedFacilityId_PWR_2008_12_01T11_32_23Z_1.xml

EncodedFacilityId_FAC_2008_12_01T11_32_23Z_1.xml

The aggregated zip files will be transferred in the following naming convention:

{EncodedFacilityId}_{dateTimes}.zip {dateTimes} – being the time of creation of the zip file

Example: EncodedFacilityId_2008_12_01T11_32_23Z.zip. This will also ensure that all aggregated files are unique and current as well as historical data, if required can be transmitted in a single package.

The process flow between wind aggregated generating facilities and the AESO is:

1. A zipped file containing the MET, PWR and/or FAC is created at the facilities.
2. Facilities connect using the secure FTP mailbox and send the file(s) to the AESO B2B Server
3. A zipped file containing either the MET and PWR or MET, PWR and FAC is sent to the AESO B2B server.
4. If there are communication errors during the connection, facilities will retry the send until successful. During the on-ramp process facilities will supply support contact information so the AESO can contact the facility if the problem persists.
5. The AESO suggest that facilities operators keep a week of data that has been sent in the event the AESO finds errors.

Detailed secure FTP specifications for facilities will be supplied during the onramp process. However, in section 4.1 there is an overview of the FTP and parameters. The backup solution for data transfer is Secure Webservices.

Facilities' user name and password is to be supplied to the AESO in a separate email during the onramp process.

3.4.2 Meteorological (MET) Data

3.4.2.1 Data Definitions for Meteorological Data

The following table describes the meteorological information required from wind aggregated generating facilities:

Measurement	Units	Precision for Instantaneous Measurements (to the nearest...)	Range	Notes	Required /Optional
Meteorological Tower Unique ID		N/A	N/A {Recommendation is to use facility ID	This is a unique ID, facility specific to depict multiple Met	R

			followed by measurement height and perhaps GPS co-ordinates.}	towers. (This should match up with the ID in the facility schema)	
Wind Speed	Meters/Second (m/s)	0.1 m/s	0 to 50	10 minute average	R
Wind Direction	Degrees from True North	1 degree	0 to 360	10 minute average	R
Surface Pressure	HectoPascals (HPa)	1 hPa	800 to 1100	10 minute average	R
Temperature	Degree Celsius	0.1° C	-50 to +50	10 minute average	R
Dewpoint	Degrees Celsius (°C)	0.1° C	-50 to +50	10 minute average	O
Relative Humidity	(Percentage)	1.0 %	0 to 100 %	10 minute average	O
Ice-up Parameter	Scale 0.0 to 1.0	0.1° C	0 to 1	10 minute average	O

3.4.2.2 Logical Data Model for Meteorological Data

The following table describes the logical domain model of the message to be used by the wind aggregated generating facilities to provide meteorological information.

Data Name	Description	Depth Level	Looping	Data Type	Constraints	Notes	Required /Optional
Facility Met Data		1	N	N/A			R
Facility	Encoded Facility ID.	2	N	String	Length = 255	AESO will provide the ID for specific Facility during the on-ramping process.	R
Transaction	Generated by the B2B	2	N	String	Will be inserted by	This is the unique transaction ID	O,R – AESO

ID	provider.				the AESO B2B provider upon reception of transmission of data.	used by the AESO B2B Service.	B2B provider is required to insert
Position ID	This is generated by the facility.	2	N	Number	Min=1 Max=6 Please refer to section 3.4.5 for values.	See 3.4.5 Hourly Position Description	R
Time Stamps	Data transmission trace	2	Y	N/A			R
Source	Source organization of the transmission	3	N	String	"Wind facility" or "B2B Provider" or "Wind Forecaster" or "AESO"	In this guide this will always be "facility".	R
Activity	Transmission activity	3	N	String	"Send", "Receive" or "Process"	In this guide it will always be "Process"	R
Time Stamp	Timestamp of the transmission	3	N	DateTime	ISO 8601 format in UTC time zone	This is the transaction time of the send process generated by the facility when sending the data.	R
Met Tower Data		2	Y	N/A			R
Meteorological Tower	Concatenation of	3	N	String	Length = 90	This tag was created to	R

Unique ID	Encoded Facility ID and Land Co-ordinates [EncodedFacilityID][LandCoOrdinates]					accommodate multiple met towers at different heights and locations. Note however only one measurement point is required.	
Wind Speed		3	N	Float	Min=0 .0Max=50.0	10 minute average	R
Wind Direction		3	N	Float	Min=0.0 Max=360.0	10 minute average, please note that if it blows N for half and E for half, the average of the NE should be provided. In some wind events, wind can blow N then S, the AESO recommends providing the value with the higher wind speed as this usually indicates an incoming system.	R
Surface Pressure		3	N	Float	Min=800.0 Max=1100.0	10 minute average	R
Temperature		3	N	Float	Min=-50.0 Max=50.0	10 minute average	R
DewPoint		3	N	Float	Min=-50.0 Max=50.0	10 minute average	O

Relative Humidity		3	N	Float	Min=0.0 Max=100.0	10 minute average	O
Ice up Parameter		3	N	Float	Min=0.0 Max=1.0		O

3.4.3 Power (PWR) Data

3.4.3.1 Data Definitions for Power Data

The following table describes the power output information that is required to be provided by the wind aggregated generating facilities.

Measurement	Units	Precision for Instantaneous Measurements (to the nearest...)	Range	Notes	Required /Optional
Current Turbine Availability (CTA)	MW	0.1 MW	Greater Than 0	Outage-related temporary reduction in Maximum Capacity (in MW) for an aggregated generating facility. In normal operations, CTA = MC.	R
Real Power Limit	MW	0.1 MW	Greater Than 0	The current value in the power limiting control system at the wind aggregated facilities.	R
Net To Grid	MW	0.1 MW	Greater Than 0	The real power output (MW) at the point of connection.	R

3.4.3.2 Logical Data Model for Power Data

The following table describes the logical domain model of the message to be used by the wind aggregated generating facilities to provide power information.

Data Name	Description	Depth Level	Looping	Data Type	Constraints	Notes	Required /Optional
Facility Power Data		1	N	N/A			R
Facility	Encoded Facility ID. AESO will	2	N	String	Length = 255	AESO will provide the ID for	R

	provide the ID for each specific Facility					specific Facility during the on-ramping process.	
Transaction ID	Generated by the B2B provider.	2	N	String	Will be inserted by the AESO B2B Provider upon reception of transmission of data.	This is the unique transaction ID used by the AESO B2B Service.	O, R AESO B2B provider is required to insert
Position ID	See 3.4.5 Hourly Position Description	2	N	Number	Min=1 Max=6	See 3.4.5 Hourly Position Description	R
Time Stamps	Data transmission trace	2	Y	N/A			R
Source	Source organization of the transmission	3	N	String	"Facility" or "B2B Provider" or "Wind Forecaster" or "AESO"	In this Information document this will always be "Facility".	R
Activity	Transmission activity	3	N	String	"Send", "Receive" or "Process"	In this Information Document it will always be "Process"	R
Time Stamp	Timestamp of the transmission	3	N	DateTime	ISO 8601 format in UTC time zone	This is the transaction time of the send process	R

						generated by the facility when sending the data.	
Current Turbine Availability (CTA)	Outage-related temporary reduction in Maximum Capacity (in MW) for an aggregated generating facility	2	N	Float	Min=0.0	In normal operations, CTA = MC.	R
Real Power Limit	The current value in the power limiting control system at the wind aggregated facilities	2	N	Float	Min=0.0	.	R
Net To Grid	The real power output (MW) at the point of connection	2	N	Float	Min=0.0	.	R

3.4.4 Facility (FAC) Data

The following table describes the information that is required to be provided by the wind aggregated generating facility. These data elements are required to be provided whenever there is a change in the value. Additionally, the Planned Turbine Availability is required to be provided whenever a new value has become available (144 hours upcoming). The FAC data needs to be provided by the wind aggregated generating facilities at least once per day (to best ensure accuracy of the 6 day ahead Forecasts).

Measurement	Units	Precision for Instantaneous Measurements (to the nearest...)	Range	Notes	Required /Optional
-------------	-------	--	-------	-------	--------------------

Planned Turbine Availability (PTA)	MW	0.1 MW	Greater Than 0	(PTA) Planned temporary reduction in Maximum Capacity (in MW) for a facility during the next 144 hours (6 days). In normal operations, PTA = MC.	R
Meteorological Tower Unique ID	N/A	N/A	N/A	{Recommendation is to use facility ID followed by measurement height and perhaps GPS co-ordinates.} This is a unique ID, Facility specific to depict multiple Met towers. (This should match up with the ID in the Metrological schema)	R
Meteorological Tower Data Collection Height	Meters	1 Meter		The height at which the meteorological data is measured at.	R
Turbine Model Name	Name		Length=255	The manufacturer's turbine model name.	R
Turbine Model Capacity	KW	0.1KW	Min=1 Max=100000	The manufacturer's turbine model capacity. As set for production.	R
Turbine Wind Cut-In	Meters/Second (m/s)	0.1 m/s	0 to 50	The manufacturer's turbine wind cut-in point. As set for production.	R

Turbine Wind Cut-Out	Meters/Second (m/s)	0.1 m/s	0 to 50	The manufacturer's turbine wind cut-out point. As set for production.	R
Turbine TemperatureCut-Out Lower*	Degree Celsius	1° C	-50 to +50	The manufacturer's turbine temperatureCut-out lower point.	R
Turbine TemperatureCut-Out Upper*	Degree Celsius	1° C	-50 to +50	The manufacturer's turbine temperatureCut-out upper point.	R

Note: There is normally a lower and higher temperature cutout. Both are relevant in Alberta. The AESO requires an indicator to confirm that the numbers are ambient temperature within the rotor or air temperature.

3.4.4.1 Logical Data Model for Facility Data

The following table describes the recommended logical domain model to be used by the wind aggregated generating facilities to provide facility information:

Data Name	Description	Depth Level	Looping	Data Type	Constraints	Notes	Required /Optional
Facility Data		1	N	N/A			R
Facility	AESO will provide the ID for specific Facility during the on-ramping process	2	N	String	Length = 255	.	R
Transaction ID	This is the unique transaction ID used by the AESO B2B Service.	2	N	String	TBD	Generated by the AESO B2B provider.	O, R AESO B2B provider is required to insert
TimeStamps	Data transmissio	2	Y	N/A			R

	n trace						
Source	Source organization of the transmission	3	N	String	" Facility" or "B2B Provider" or "Wind Forecaster" or "AESO"	In this guide this will always be "Facility".	R
Activity	Transmission activity	3	N	String	"Send", "Receive" or "Process"	In this guide it will always be "Process"	R
TimeStamp	Timestamp of the transmission	3	N	DateTime	ISO 8601 format in UTC time zone	This is the transaction time of the send process generated by the facility when sending the data.	R
Planned Turbine Availability	(PTA) Planned temporary reduction in Maximum Capacity (in MW) for a facility during the next 144 hours (6 days).	2	Y	N/A		In normal operations, PTA = MC	O
Start Date	Beginning data time of the period of	3	N	DateTime	ISO 8601 format in UTC time		R

	planned turbine availability				zone		
End Date	End date time of the period of planned turbine availability	3	N	DateTime	ISO 8601 format in UTC time zone		R
MegaWatts	Hourly weighted average planned turbine availability. See following section for example.	3	N	Float	> 0.0	The real power that would have been produced at the point of connection without any facility curtailment and based on real time meteorological conditions at each available wind turbine generator.	R
Meteorological Tower Data		2	Y	N/A			O, R if more than one towers are used
Meteorological Tower Unique ID	Concatenation of Encoded Facility ID and Land Co-ordinates	3	N	String	Length = 90	{Recommendation is to use Facility ID followed by measurement height	O, R if more than one tower is used and/or if there is data to be

	[EncodedFacilityID][LandCoOrdinates]					and perhaps GPS coordinates. This is a unique ID, facility specific to depict multiple Met towers. (This should match up with the ID in the Meteorological schema)	reported.
Meteorological Tower Data Collection Height	The height at which the meteorological data is measured at.	3	N	Float			R
Turbine Land Data		2	Y				O
Turbine Model Name	The manufacturer's turbine model name.	3	N	String	Length=255		R
Turbine Model Capacity	The manufacturer's turbine model capacity. As set for production	3	N	Number	Min=1 Max=100000	.	R
Turbine Wind CutIn	The manufacturer's turbine	3	N	Float			R

	wind cut-in point. As set for production.						
Turbine Wind Cut Out	The manufacturer's turbine wind cut-out point. As set for production.	3	N	Number			R
Turbine Temperature Cut Out Lower	The manufacturer's turbine temperature Cut-out lower point.	3	N	Float	Min=-50 Max=50		R
Turbine Temperature Cut Out Upper	The manufacturer's turbine temperature Cut-out upper point	3	N	Float	Min=-50 Max=50	.	R

3.4.4.2 Wind Aggregated Generating Turbine Availability Example

The Planned Turbine availability data is expected to be reported to the hour based on a time range of 6 days (144 hours).

Example: When there is no planned outage for facility; the following planned turbine availability should be provided to AESO:

Start = 2010-12-01T13:00Z

End = 2010-12-07T13:00Z

MW = 82 (MC @ 2 MW per turbine X 41 turbines)

Example: When there is planned outage for one turbine between 2010 12 01 13:40 to 16:10. The following planned turbine availability should be provided to AESO:

1st hour of outage

Start = 2010-12-01T13:00Z

End = 2010-12-01T14:00Z

MW = 81 ($82 - 2 * 20 / 60 = 81.3$)

2nd hour of outage

Start = 2010-12-01T14:00Z

End = 2010-12-01T15:00Z

MW = 80 (82-2)

3rd hour of outage

Start = 2010-12-01T15:00Z

End = 2010-12-01T16:00Z

MW = 80 (82-2)

4th and final hour of outage

Start = 2010-12-01T16:00Z

End = 2010-12-01T17:00Z

MW = 82 ($82 - 2 * 10 / 60 = 81.7$)

3.4.5 Hourly Position Description

The Position ID is the indicator of which 10 minute span within an hour is being aggregated in any given transaction.

PositionID	Time Range of Data Process by Facility	Time Range of Transmission by Facility	AESO B2B Aggregates and Sends to WEPROG	Description
1	00:00 – 09:59	XXh:10:00 – 12:59	XXh:13:00 – 13:59	MM:SS
2	10:00 – 19:59	XXh:20:00 – 22:59	XXh:23:00 – 23:59	MM:SS
3	20:00 – 29:59	XXh:30:00 – 32:59	XXh:33:00 – 33:59	MM:SS
4	30:00 – 39:59	XXh:40:00 – 42:59	XXh:43:00 – 43:59	MM:SS
5	40:00 – 49:59	XXh:50:00 – 52:59	XXh:53:00 – 53:59	MM:SS
6	50:00 – 59:59	XXh:00:00 – (XXh +1):02:59	(XXh: +1):03:00– (XXh +1):03:59	MM:SS

3.4.6 Data Transmission Timeline

The following are the requirements for the data transfer timeline:

- The MET and PWR data needs to be measured and provided by the wind aggregated generating facilities operator at the end of every 10 minute period.
- The maximum allowed tolerance to transfer this data over to the AESO B2B provider, is 3 minutes. Facilities should, and report any failure to the AESO at each instance.
- In case of the delays or outage, the facilities should ensure that the data is sent to the AESO B2B provider after the fact.

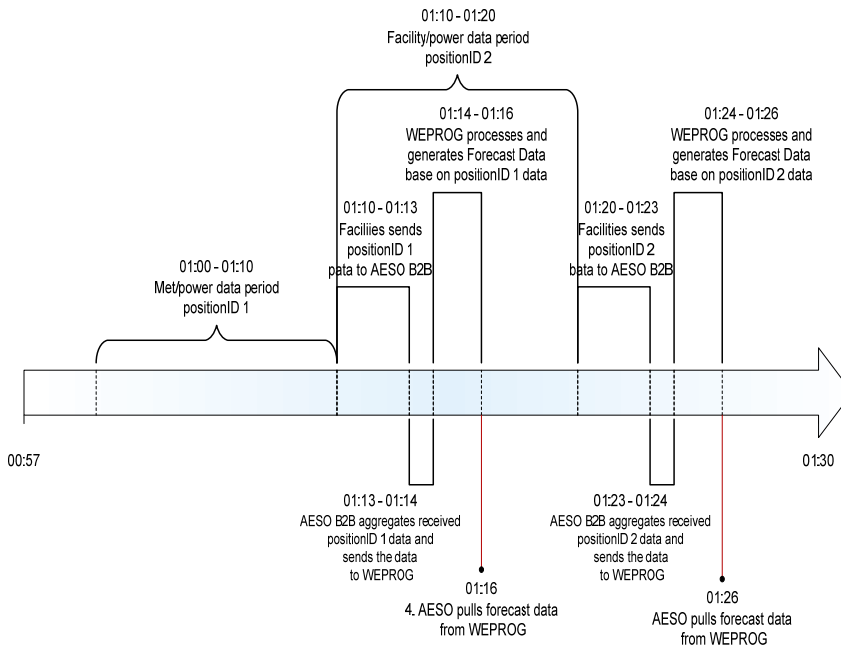

3.4.7 Software/Security Updates

Computer system hardware and software should be maintained and upgraded, per manufacturer’s recommendations.

3.4.8 Errors and Alerting

Error and Alerting is being implemented by the AESO, however, it is not required by the wind aggregated generating Facilities to produce error codes for the AESO B2B Service and/or the Forecaster.

4 Appendix A – Data Transfer Technical Specification

This specification provides details of the standard formats and protocols to be followed to enable data exchange between wind aggregated generating facilities and the AESO.

4.1 Secure FTP

4.1.1 Connection Details

AESO B2B SFTP Server Address: <sftp.tradinggrid.gxs.com>

Port Number: 22

User/Password: {to be obtained during on-ramping process}

If using Public Key authentication, exchange public keys with GXS.

4.1.2 Virtual File System

The AESO B2B Service has implemented a virtual file system for SFTP. File name path follows the following convention:

/user/partner/opt1/opt2

- User – is the signed-on facility. After login, the user is in its home directory.
- Partner – is the trading partner and has a corresponding directory under the home directory. The partner directory contains all files received from or sent to this partner.
- Opt1 (optional) – document type or ARPF depends on the command used.
- Opt2 (optional) – control number of document status depends on the command used.

4.1.3 Commands

The following SFTP commands can be used to upload the MET, PWR and FAC data to the AESO B2B.

- pwd – show current virtual file name path
- cd – change directory
- put – to upload document to partner

Note: During the On-Ramping Process, detailed commands and uses will be provided and configured with each wind aggregated generating facility.

4.2 Secure Web Services

The wind aggregated generating facilities are to use a Secure Web Service provided by the AESO to transfer the MET, PWR and FAC data. MET, PWR and FAC data has to be made available as XML documents, as per the individual message schemas provided later in this Information Document. The Web service can be implemented with any Web services technology. Adherence to this specification guarantees interoperability regardless of the chosen technology platform.

Note: That individual .xml files will need to be sent to the AESO B2B Webservice **NOT** consolidated into a zip file like the sFTP service.

Specific security protocols will be given on a one-to-one basis while on-ramping each aggregated generating facility to ensure protection of security information. The AESO B2B Provider has Secure Socket Layer (SSL) for encrypted sessions of HTTP and Secure FTP (SFTP and FTPs). All data is also transferred through AESO B2B commercial firewalls.

4.2.1 AESO B2B Provider Web Service Specification

The following Web Service is provided by the AESO B2B Provider. This service will be primarily used by the wind aggregated generating facilities to submit MET, PWR and FAC specific data to the AESO B2B Provider.

List of services provided by AESO:

Service Name	Functionality
mailboxList	Provides the list of items in their mailbox
getLogEntries	Returns the activity log entries for a document with a particular document ID.
requeueDocument	Re-queues the document with a particular document ID.
upload	Uploads a document to the AESO B2B Provider.
download	Downloads a document from AESO B2B Provider.

4.2.1.1 Upload Service

Each of the wind aggregated generated facilities are to use the “upload” service from the AESO B2B Provider to submit MET, PWR and FAC data.

The following parameters are required to be provided as input to the “upload” service:

Parameter	Description
Userid	Enterprise Mailbox ID of the sender
receiverid	Enterprise Mailbox ID of the Receiver.
Datatype	Optional. It can be EDI, XML or Binary. XML will be the chosen option.
Aprf	Optional. Application reference.
Snrf	Optional. Document control number.
Destination	Optional. 'ICSCSR' is default;
InputData	The inputData that needs to be uploaded.

The following parameters will be provided as output from the “upload” service.

Parameter	Description
DocTimeStamp	To be given during on-ramp process.
InternalID	To be given during on-ramp process.

SERVICEREF	To be given during on-ramp process.
LogEntry	To be given during on-ramp process.

4.2.2 Web Service Description Language

Web Service Description Language (WSDL) is used to describe the technical details of each message and operation defined in the service to be called. The WSDL below describes the AESO's B2B Web service that serves as a common interface for wind aggregated generating facilities.

The following is the WSDL describing various the "upload" service hosted by the AESO B2B Service to be used by the operator of wind aggregated generating facilities to submit MET, PWR, and FAC data.

```
<?xml version="1.0" encoding="UTF-8"?>
```

```
<wsdl:definitions name="gxs_ws_comm" targetNamespace="http://icslinux7/" xmlns:tns="http://icslinux7/"
xmlns:mime="http://schemas.xmlsoap.org/wsdl/mime/"
xmlns:http="http://schemas.xmlsoap.org/wsdl/http/" xmlns:xsd="http://www.w3.org/2001/XMLSchema"
xmlns:soap="http://schemas.xmlsoap.org/wsdl/soap/" xmlns:wSDL="http://schemas.xmlsoap.org/wsdl/">
```

```
<wsdl:types>
```

```
<xsd:schema targetNamespace="http://localhost/gxs/ws/comm/upload"
xmlns:tns="http://localhost/gxs/ws/comm/upload" xmlns:xsd="http://www.w3.org/2001/XMLSchema">
```

```
<xsd:complexType name="__uploadInput">
```

```
<xsd:sequence>
```

```
<xsd:element name="inputData" nillable="true" type="xsd:string"/>
```

```
<xsd:element name="userid" nillable="true" type="xsd:string"/>
```

```
<xsd:element name="receiverid" nillable="true" type="xsd:string"/>
```

```
<xsd:element minOccurs="0" name="datatype" nillable="true" type="xsd:string"/>
```

```
<xsd:element minOccurs="0" name="aprf" nillable="true" type="xsd:string"/>
```

```
<xsd:element minOccurs="0" name="snrf" nillable="true" type="xsd:string"/>
```

```
<xsd:element name="destination" nillable="true" type="xsd:string"/>
```

```
</xsd:sequence>
```

```
</xsd:complexType>
```

```
<xsd:complexType name="__uploadOutput">
```

```
<xsd:sequence>
```

```
<xsd:element name="DocTimestamp" nillable="true" type="xsd:string"/>
```

```

<xsd:element name="InternalID" nillable="true" type="xsd:string"/>
<xsd:element name="SERVICEREF" nillable="true" type="xsd:string"/>
<xsd:element name="LogEntry" nillable="true" type="xsd:string"/>
</xsd:sequence>
</xsd:complexType>
</xsd:schema>
</wsdl:types>
<wsdl:message name="_uploadOutput">
  <wsdl:part name="DocTimestamp" type="xsd:string"/>
  <wsdl:part name="InternalID" type="xsd:string"/>
  <wsdl:part name="SERVICEREF" type="xsd:string"/>
  <wsdl:part name="LogEntry" type="xsd:string"/>
</wsdl:message>
<wsdl:message name="_uploadInput">
  <wsdl:part name="inputData" type="xsd:string"/>
  <wsdl:part name="userid" type="xsd:string"/>
  <wsdl:part name="receiverid" type="xsd:string"/>
  <wsdl:part name="datatype" type="xsd:string"/>
  <wsdl:part name="aprf" type="xsd:string"/>
  <wsdl:part name="snrf" type="xsd:string"/>
  <wsdl:part name="destination" type="xsd:string"/>
</wsdl:message>
<wsdl:portType name="gxs_ws_commPortType">
  <wsdl:operation name="upload">
    <wsdl:input message="tns:_uploadInput"/>
    <wsdl:output message="tns:_uploadOutput"/>
  </wsdl:operation>

```

```

</wsdl:portType>

<wsdl:binding name="gxs_ws_commBinding" type="tns:gxs_ws_commPortType">
  <soap:binding style="rpc" transport="http://schemas.xmlsoap.org/soap/http"/>
  <wsdl:operation name="upload">
    <soap:operation soapAction=""/>
    <wsdl:input>
      <soap:body use="encoded" encodingStyle="http://schemas.xmlsoap.org/soap/encoding/"
namespace="http://icslinux7/gxs.ws.comm"/>
    </wsdl:input>
    <wsdl:output>
      <soap:body use="encoded" encodingStyle="http://schemas.xmlsoap.org/soap/encoding/"
namespace="http://icslinux7/gxs.ws.comm"/>
    </wsdl:output>
  </wsdl:operation>
</wsdl:binding>

<wsdl:service name="gxs_ws_commService">
  <wsdl:port name="gxs_ws_commPort0" binding="tns:gxs_ws_commBinding">
    <soap:address location="https://ws.tradinggrid.gxs.com:443/smg/ws_comm/upload"/>
  </wsdl:port>
</wsdl:service>
</wsdl:definitions>

```

5 Appendix B – Message Formats - XSD

5.1 Met Data Schema

The following schema is used for all Meteorological Data and each wind aggregated facility is required to translate their data into the format below.

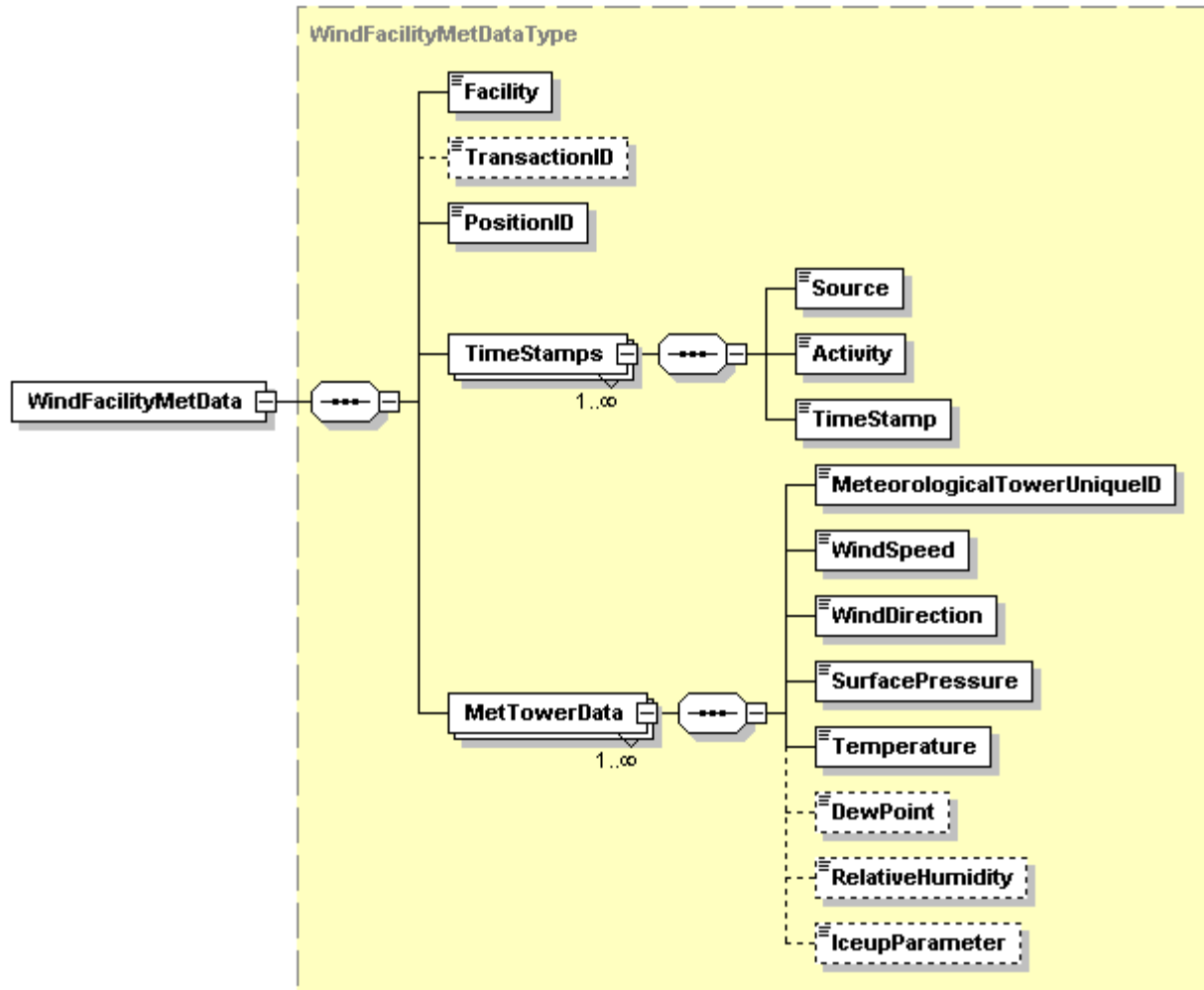

```
<?xml version="1.0" encoding="UTF-8"?>
```

```
<xs:schema xmlns:xs="http://www.w3.org/2001/XMLSchema"
  xmlns="http://windforecasting.public.aeso.ca" targetNamespace="http://windforecasting.public.aeso.ca"
  elementFormDefault="qualified" attributeFormDefault="unqualified">
```

```
<xs:element name="WindFacilityMetData" type="WindFacilityMetDataType"/>
```

```
<xs:complexType name="WindFacilityMetDataType">
```

```
<xs:sequence>
```

```
<xs:element name="Facility">
```

```

<xs:simpleType>
  <xs:restriction base="xs:string">
    <xs:maxLength value="255"/>
  </xs:restriction>
</xs:simpleType>
</xs:element>
<xs:element name="TransactionID" type="xs:string" minOccurs="0"/>
<xs:element name="PositionID">
  <xs:simpleType>
    <xs:restriction base="xs:integer">
      <xs:minInclusive value="1"/>
      <xs:maxInclusive value="6"/>
    </xs:restriction>
  </xs:simpleType>
</xs:element>
<xs:element name="TimeStamps" maxOccurs="unbounded">
  <xs:complexType>
    <xs:sequence>
      <xs:element name="Source">
        <xs:simpleType>
          <xs:restriction base="xs:string">
            <xs:enumeration value="Wind Facility"/>
            <xs:enumeration value="B2B Provider"/>
            <xs:enumeration value="Wind Forecaster"/>
            <xs:enumeration value="AESO"/>
          </xs:restriction>
        </xs:simpleType>
      </xs:element>
    </xs:sequence>
  </xs:complexType>
</xs:element>

```

```

</xs:element>

<xs:element name="Activity">
  <xs:simpleType>
    <xs:restriction base="xs:string">
      <xs:enumeration value="Send"/>
      <xs:enumeration value="Receive"/>
      <xs:enumeration value="Process"/>
    </xs:restriction>
  </xs:simpleType>
</xs:element>

<xs:element name="TimeStamp" type="xs:dateTime"/>

</xs:sequence>

</xs:complexType>

</xs:element>

<xs:element name="MetTowerData" maxOccurs="unbounded">
  <xs:complexType>
    <xs:sequence>
      <xs:element name="MeteorologicalTowerUniqueID">
        <xs:simpleType>
          <xs:restriction base="xs:string">
            <xs:minLength value="0"/>
            <xs:maxLength value="90"/>
          </xs:restriction>
        </xs:simpleType>
      </xs:element>
      <xs:element name="WindSpeed">
        <xs:simpleType>

```

```

<xs:restriction base="xs:float">
  <xs:minInclusive value="0"/>
  <xs:maxInclusive value="50"/>
</xs:restriction>
</xs:simpleType>
</xs:element>
<xs:element name="WindDirection">
  <xs:simpleType>
    <xs:restriction base="xs:float">
      <xs:minInclusive value="0"/>
      <xs:maxInclusive value="360"/>
    </xs:restriction>
  </xs:simpleType>
</xs:element>
<xs:element name="SurfacePressure">
  <xs:simpleType>
    <xs:restriction base="xs:float">
      <xs:minInclusive value="800"/>
      <xs:maxInclusive value="1100"/>
    </xs:restriction>
  </xs:simpleType>
</xs:element>
<xs:element name="Temperature">
  <xs:simpleType>
    <xs:restriction base="xs:float">
      <xs:minInclusive value="-50"/>
      <xs:maxInclusive value="50"/>
    </xs:restriction>
  </xs:simpleType>
</xs:element>

```

```

    </xs:restriction>
  </xs:simpleType>
</xs:element>
<xs:element name="DewPoint" minOccurs="0">
  <xs:simpleType>
    <xs:restriction base="xs:float">
      <xs:minInclusive value="-50"/>
      <xs:maxInclusive value="50"/>
    </xs:restriction>
  </xs:simpleType>
</xs:element>
<xs:element name="RelativeHumidity" minOccurs="0">
  <xs:simpleType>
    <xs:restriction base="xs:float">
      <xs:minInclusive value="0"/>
      <xs:maxInclusive value="100"/>
    </xs:restriction>
  </xs:simpleType>
</xs:element>
<xs:element name="IceupParameter" minOccurs="0">
  <xs:simpleType>
    <xs:restriction base="xs:float">
      <xs:minInclusive value="0"/>
      <xs:maxInclusive value="1"/>
    </xs:restriction>
  </xs:simpleType>
</xs:element>

```

```

</xs:sequence>

</xs:complexType>

</xs:element>

</xs:sequence>

</xs:complexType>

</xs:schema>

```

5.2 Power Data Schema

The following schema is used for all Power Data and each wind aggregated facility is required to translate their data into the format below.

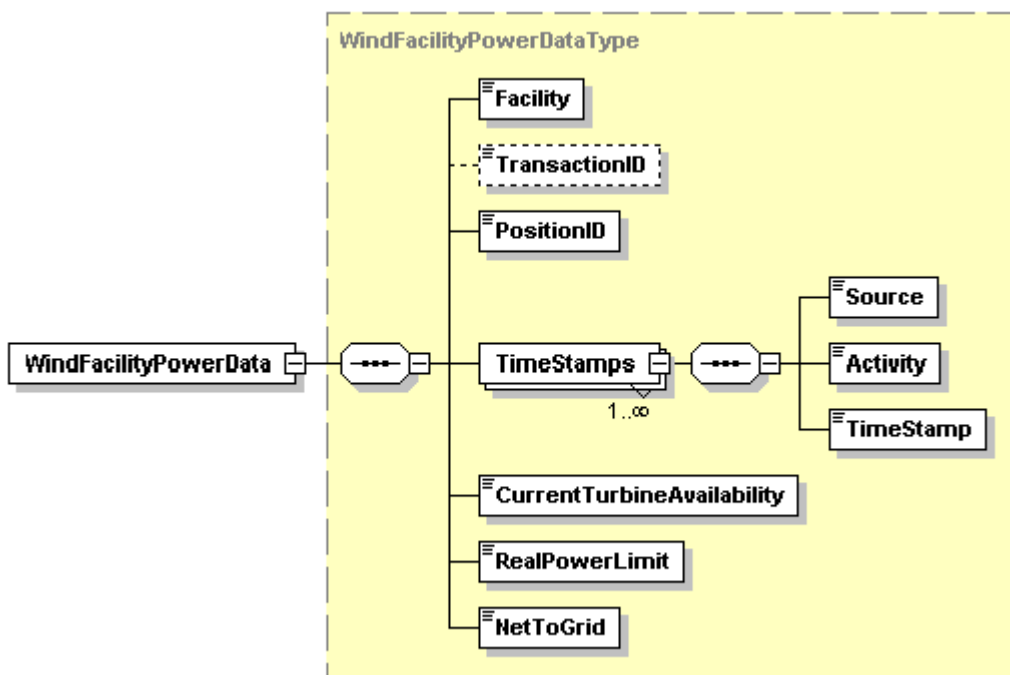

```

<?xml version="1.0" encoding="UTF-8"?>

<xs:schema xmlns:xs="http://www.w3.org/2001/XMLSchema"
xmlns="http://windforecasting.public.aeso.ca" targetNamespace="http://windforecasting.public.aeso.ca"
elementFormDefault="qualified" attributeFormDefault="unqualified">

  <xs:element name="WindFacilityPowerData" type="WindFacilityPowerDataType"/>

  <xs:complexType name="WindFacilityPowerDataType">

    <xs:sequence>

      <xs:element name="Facility">

```

```

<xs:simpleType>
  <xs:restriction base="xs:string">
    <xs:maxLength value="255"/>
  </xs:restriction>
</xs:simpleType>
</xs:element>
<xs:element name="TransactionID" type="xs:string" minOccurs="0"/>
<xs:element name="PositionID">
  <xs:simpleType>
    <xs:restriction base="xs:integer">
      <xs:minInclusive value="1"/>
      <xs:maxInclusive value="6"/>
    </xs:restriction>
  </xs:simpleType>
</xs:element>
<xs:element name="TimeStamps" maxOccurs="unbounded">
  <xs:complexType>
    <xs:sequence>
      <xs:element name="Source">
        <xs:simpleType>
          <xs:restriction base="xs:string">
            <xs:enumeration value="Wind Facility"/>
            <xs:enumeration value="B2B Provider"/>
            <xs:enumeration value="Wind Forecaster"/>
            <xs:enumeration value="AESO"/>
          </xs:restriction>
        </xs:simpleType>
      </xs:element>
    </xs:sequence>
  </xs:complexType>
</xs:element>

```

```

</xs:element>

<xs:element name="Activity">
  <xs:simpleType>
    <xs:restriction base="xs:string">
      <xs:enumeration value="Send"/>
      <xs:enumeration value="Receive"/>
      <xs:enumeration value="Process"/>
    </xs:restriction>
  </xs:simpleType>
</xs:element>

<xs:element name="TimeStamp" type="xs:dateTime"/>

</xs:sequence>

</xs:complexType>

</xs:element>

<xs:element name="CurrentTurbineAvailability">
  <xs:simpleType>
    <xs:restriction base="xs:float">
      <xs:minInclusive value="0"/>
    </xs:restriction>
  </xs:simpleType>
</xs:element>

<xs:element name="RealPowerLimit">
  <xs:simpleType>
    <xs:restriction base="xs:float">
      <xs:minInclusive value="0"/>
    </xs:restriction>
  </xs:simpleType>

```

```
</xs:element>  
  
<xs:element name="NetToGrid">  
  <xs:simpleType>  
    <xs:restriction base="xs:float">  
      <xs:minInclusive value="0"/>  
    </xs:restriction>  
  </xs:simpleType>  
</xs:element>  
</xs:sequence>  
</xs:complexType>  
</xs:schem
```

5.3 FAC Schema Data

The following schema is used for all Facility Data and each wind aggregated facility is required to translate their data into the format below.

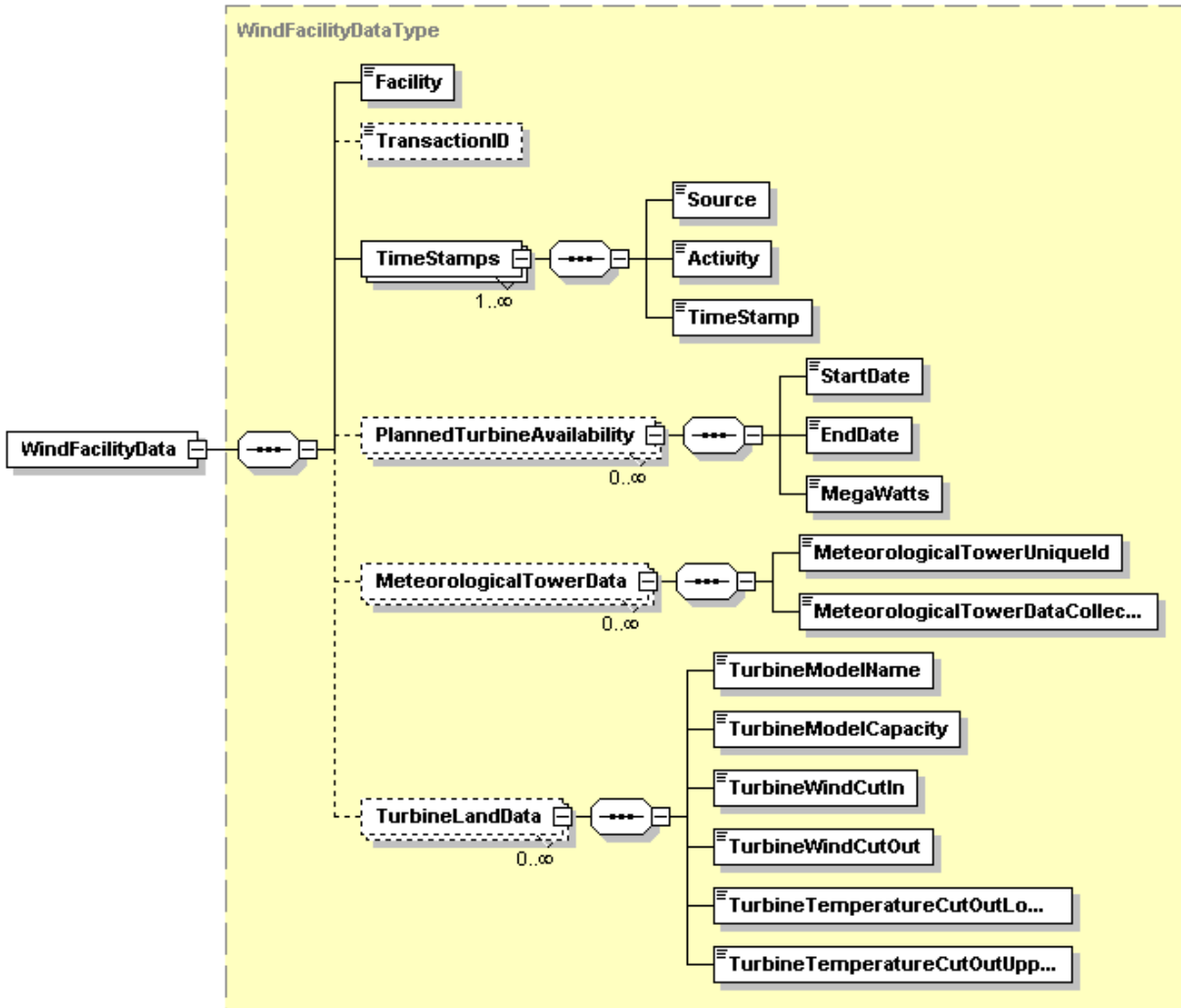

```
<?xml version="1.0" encoding="UTF-8"?>
```

```
<xs:schema xmlns:xs="http://www.w3.org/2001/XMLSchema"
xmlns="http://windforecasting.public.aeso.ca" targetNamespace="http://windforecasting.public.aeso.ca"
elementFormDefault="qualified" attributeFormDefault="unqualified">
```

```
<xs:element name="WindFacilityData" type="WindFacilityDataType"/>
```

```
<xs:complexType name="WindFacilityDataType">
```

```
<xs:sequence>
```

```
<xs:element name="Facility">
```

```
<xs:simpleType>
```

```

<xs:restriction base="xs:string">
  <xs:maxLength value="255"/>
</xs:restriction>
</xs:simpleType>
</xs:element>
<xs:element name="TransactionID" type="xs:string" minOccurs="0"/>
<xs:element name="TimeStamps" maxOccurs="unbounded">
  <xs:complexType>
    <xs:sequence>
      <xs:element name="Source">
        <xs:simpleType>
          <xs:restriction base="xs:string">
            <xs:enumeration value="Wind Facility"/>
            <xs:enumeration value="B2B Provider"/>
            <xs:enumeration value="Wind Forecaster"/>
            <xs:enumeration value="AESO"/>
          </xs:restriction>
        </xs:simpleType>
      </xs:element>
      <xs:element name="Activity">
        <xs:simpleType>
          <xs:restriction base="xs:string">
            <xs:enumeration value="Send"/>
            <xs:enumeration value="Receive"/>
            <xs:enumeration value="Process"/>
          </xs:restriction>
        </xs:simpleType>
      </xs:element>
    </xs:sequence>
  </xs:complexType>
</xs:element>

```

```

</xs:element>

  <xs:element name="TimeStamp" type="xs:dateTime"/>

</xs:sequence>

</xs:complexType>

</xs:element>

<xs:element name="PlannedTurbineAvailability" minOccurs="0" maxOccurs="unbounded">

  <xs:complexType>

    <xs:sequence>

      <xs:element name="StartDate" type="xs:dateTime"/>

      <xs:element name="EndDate" type="xs:dateTime"/>

      <xs:element name="MegaWatts" type="xs:float"/>

    </xs:sequence>

  </xs:complexType>

</xs:element>

<xs:element name="MeteorologicalTowerData" minOccurs="0" maxOccurs="unbounded">

  <xs:complexType>

    <xs:sequence>

      <xs:element name="MeteorologicalTowerUniqueId">

        <xs:simpleType>

          <xs:restriction base="xs:string">

            <xs:minLength value="0"/>

            <xs:maxLength value="90"/>

          </xs:restriction>

        </xs:simpleType>

      </xs:element>

      <xs:element name="MeteorologicalTowerDataCollectionHeight" type="xs:float"/>

    </xs:sequence>

```

```

</xs:complexType>
</xs:element>
<xs:element name="TurbineLandData" minOccurs="0" maxOccurs="unbounded">
  <xs:complexType>
    <xs:sequence>
      <xs:element name="TurbineModelName" type="xs:string"/>
      <xs:element name="TurbineModelCapacity">
        <xs:simpleType>
          <xs:restriction base="xs:integer">
            <xs:minInclusive value="1"/>
            <xs:maxInclusive value="100000"/>
          </xs:restriction>
        </xs:simpleType>
      </xs:element>
      <xs:element name="TurbineWindCutIn" type="xs:float"/>
      <xs:element name="TurbineWindCutOut" type="xs:float"/>
      <xs:element name="TurbineTemperatureCutOutLower">
        <xs:simpleType>
          <xs:restriction base="xs:float">
            <xs:minInclusive value="-50"/>
            <xs:maxInclusive value="+50"/>
          </xs:restriction>
        </xs:simpleType>
      </xs:element>
      <xs:element name="TurbineTemperatureCutOutUpper">
        <xs:simpleType>
          <xs:restriction base="xs:float">

```

```
<xs:minInclusive value="-50"/>  
<xs:maxInclusive value="50"/>  
</xs:restriction>  
</xs:simpleType>  
</xs:element>  
</xs:sequence>  
</xs:complexType>  
</xs:element>  
</xs:sequence>  
</xs:complexType>  
</xs:schema>
```

6 Appendix C – On-Ramping Instructions

Each of the wind aggregated generating facilities operators should work with the AESO B2B Service provider to on-ramp to the AESO Wind Power Forecasting Service. The AESO B2B Service will provide mapping services to each wind aggregated generating facility and support for initial on-ramping purposes. Each Facility is responsible for providing Subject Matter Experts (SME's) to meet the requirements of this Information Document.

6.1 Test and Production Environments

During the On-Ramp Process each wind aggregated generating facility will be provided test and production environments to validate their connections to the AESO Wind Power Forecasting Service.

6.2 Historical Data

Historical Data will be used to test the translations between the Wind Aggregated Generating Facility and the AESO's B2B Service. Historical data is expected to be supplied in the same format as described in this document for 'current' data. Two (2) years of data is to be supplied for testing purposes. This will be used by the Forecaster to train their system for the generation of optimal forecasts.

At this point only MET data is expected for historical purposes, however, if PWR and FAC data is available it would be used.

6.3 Technical Support

Technical Support documentation will be provided during the on-ramping process for each wind aggregated generating facility.

7 Appendix D – References

- Web Services: <http://www.w3.org/2002/ws/>
- WSDL: <http://www.w3.org/2002/ws/desc/>
-

Revision History

Version	Effective Date	Description of Changes
1.0	June 23, 2011	Initial Release