

Keephills 3 and Edmonton Region 240 kV Line Upgrades Projects
 Configuration Prior To Changes
 Based on Construction Plan of Aug 26, 2009
 Page 1 of 6

Keephills 3 Project Scope

- K1. Convert 1202L from 240 kV to 500 kV operation, with new 500 kV breakers and bus at Keephills 320P and Ellerslie 89S
- K2. Add a 240 kV 600 MVA phase shifting transformer at Keephills 320P
- K3. Construct 1.1 km of 240 kV double circuit line to re-terminate 190L and 903L at Keephills 320P
- K4. Temporary re-termination of 909L from Sundance 310P to Keephills 320P
- K5. Upgrade 240 kV protective relays and possibly 240 kV circuit breakers at various substation
- K6. Add overload mitigation systems at various substations

Edmonton Region 240 kV Line Upgrades Project Scope

- E1. Rebuild 47 km of existing 240 kV line 904L (portions of 904L will be renamed to 1043L)
- E2. Construct 12 km of new 240 kV double circuit line
- E3. Reconnect 240 kV lines 1044EL and 1045EL 'Jasper Tap' from existing 904L to 908L (908L will be renamed to 1045L)
- E4. Upgrade 24 km of conductors on 240 kV lines 1044EL and 1045EL
- E5. Upgrade 240kV bus capacity in Jasper 805S
- E6. Upgrade 9 km of conductors on 240 kV lines 908L and 909L near Sundance 310P
- E7. Upgrade 8.4 km of conductors on 240 kV line 902L near Wabamun and Sundance
- E8. Add two new 240 kV circuit breakers at Keephills 320P to re-terminate 240 kV transmission line 903L
- E9. Add 240 kV 600 MVA phase shifting transformer at Dover (not show in this diagram)
- E10. Re-terminate 909L from Keephills 320P to Sundance 310P (See scope K4 above.)
- E11. Add overload mitigation systems at various substations.

Note:

1. There are a number of intermediate construction stages not indicated.
2. The intermediate construction stages are subject to change without notice.
3. The proposed system modifications and additions are scheduled to start October 2009 and be completed by June 2011.

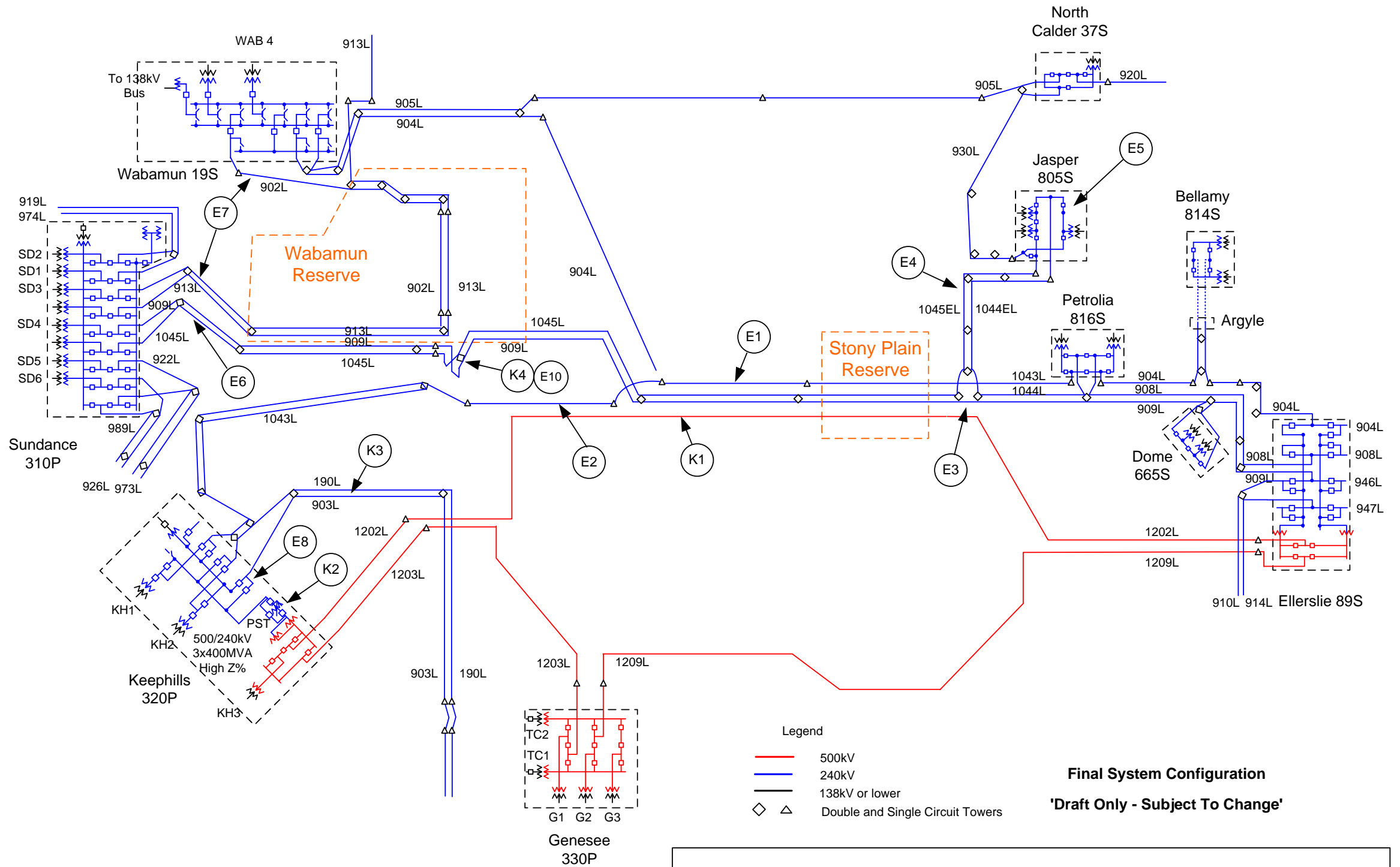

Keephills 3 and Edmonton Region 240 kV Line Upgrades Projects
Final Configuration
 Based on Construction Plan of Aug 26, 2009
 Page 2 of 6

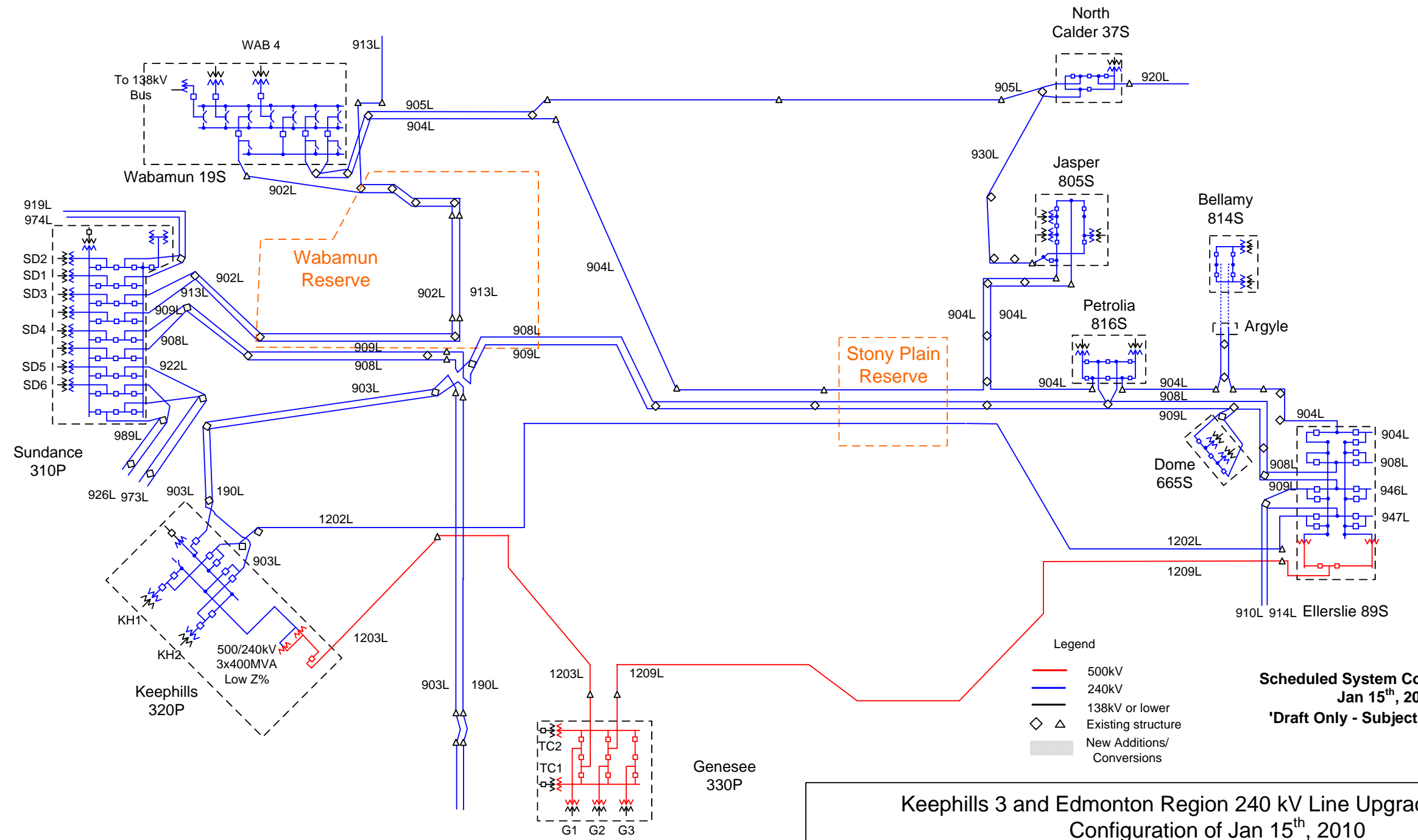

Keephills 3 and Edmonton Region 240 kV Line Upgrades Projects
Configuration of Jan 15th, 2010
 Based on Construction Plan of Aug 26, 2009
 (Note: The system configuration is the same as is shown on page 1 of 6)
 Page 3 of 6

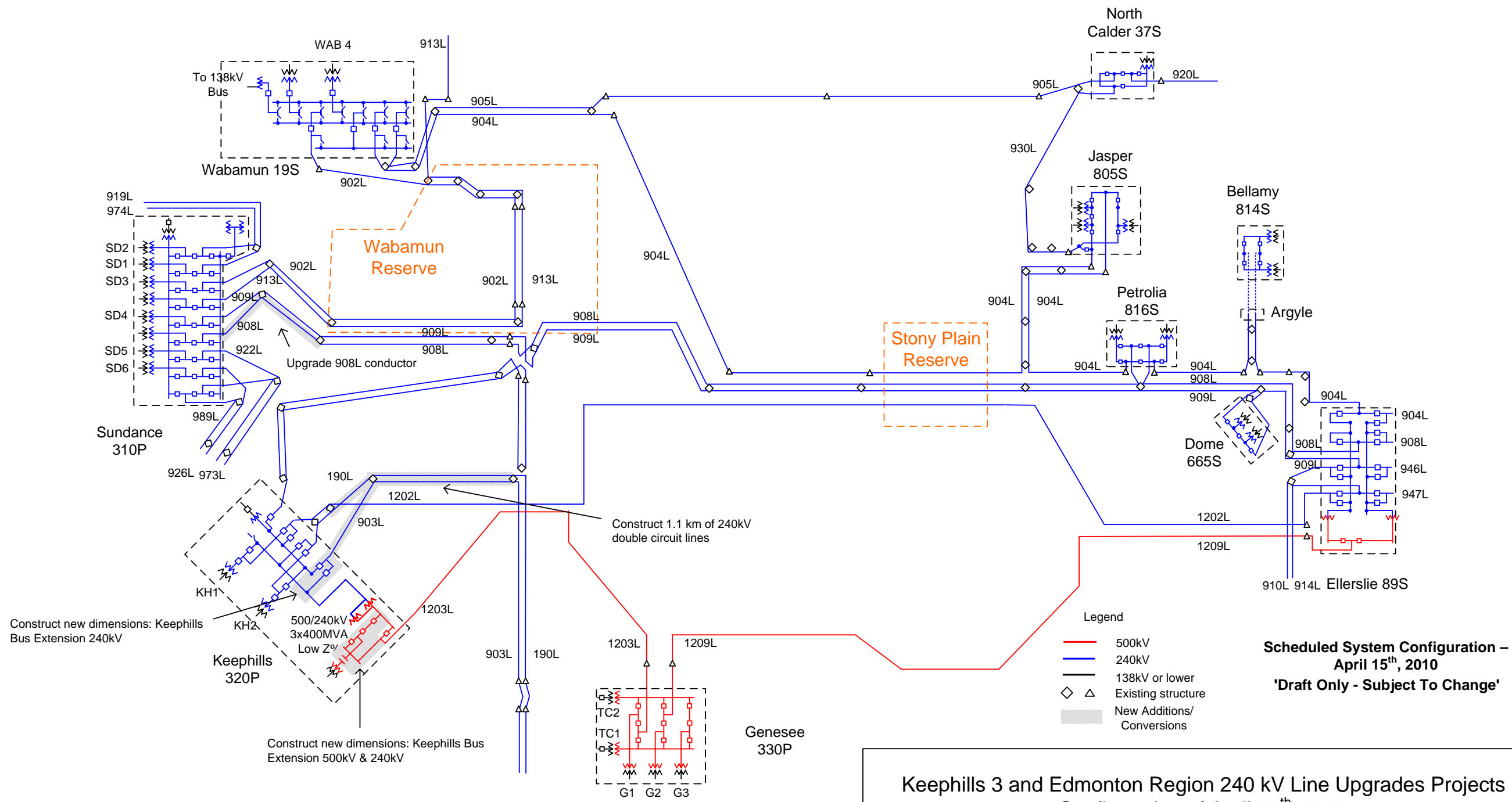

Keephills 3 and Edmonton Region 240 kV Line Upgrades Projects
 Configuration of April 15th, 2010
 Based on Construction Plan of Aug 26, 2009
 Page 4 of 6

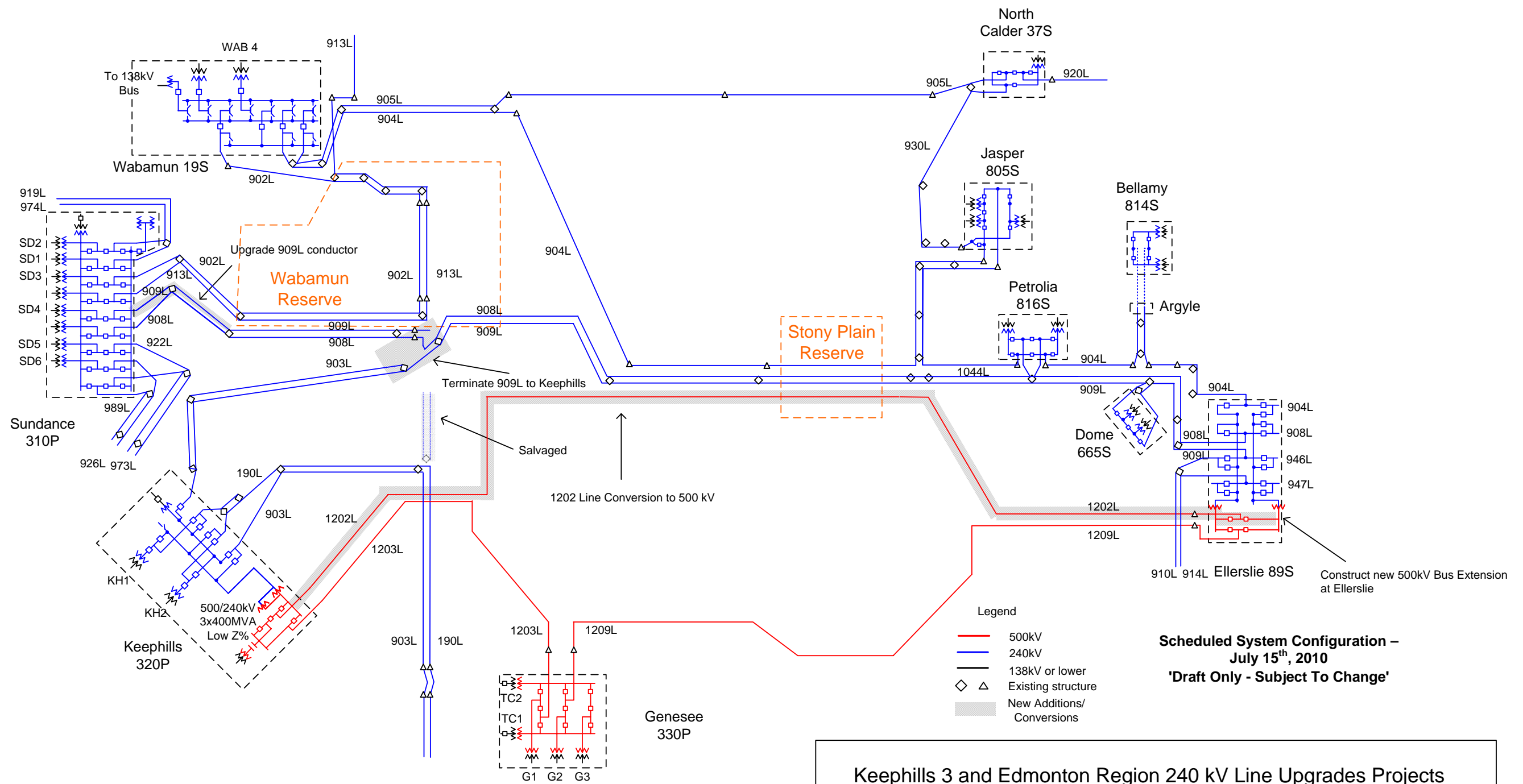

Keephills 3 and Edmonton Region 240 kV Line Upgrades Projects
 Configuration of July 15th, 2010
 Based on Construction Plan of Aug 26, 2009
 Page 5 of 6

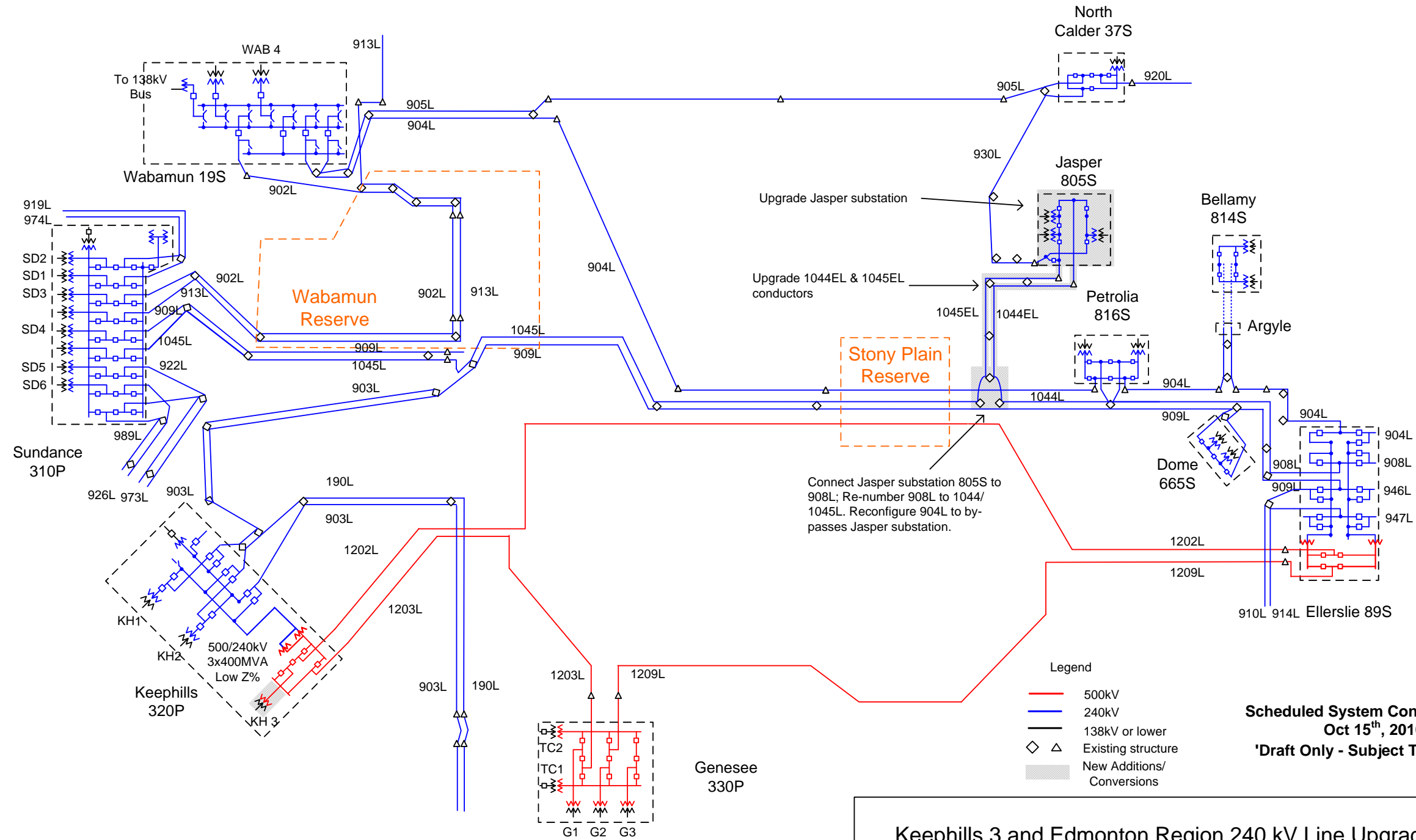

Keephills 3 and Edmonton Region 240 kV Line Upgrades Projects
 Configuration of October 15th, 2010
 Based on Construction Plan of Aug 26, 2009
 Page 6 of 6